

Philips Lumileds

IESNA LM-80 Test Report

1. Applicable LUXEON® Series part number(s)

This IESNA LM-80 Test Report applies to the following LUXEON part numbers:

Product Family	Part Number	CCT
LUXEON 3030 2D	L130-xyyy003000W21	white

In these part numbers xx designates the nominal ANSI color bin (e.g. 27 for 2700K, 30 for 3000K, etc.) and yy designates the minimum CRI value (e.g. 80 for a minimum CRI of 80).

2. L_{70} Extrapolations per IESNA TM-21-11

	If = 165mA	If = 200mA
Ts = 105°C	> 54,000	51,000
Ts = 85°C	> 54,000	> 54,000
Ts = 55°C	> 54,000	> 54,000
		= Limited by TM-21 6x rule

3. Number of LED light sources tested

50 units tested per stress condition / data reported for first 25 units per test condition.

4. Description of LED light sources tested

LUXEON 3030 2D: L130-2780003000W21 (nominal CCT 2700K)

5. Dates Tests Started

All DATA SETs: 03-23-2014.

6. Date Report First Issued

All DATA SETs: first reported on 01-20-2015.

7. Package Pictures



Figure 1. Picture of LUXEON 3030 2D.

8. Mechanical Drawing

For detailed mechanical drawings, please see individual product data sheets.

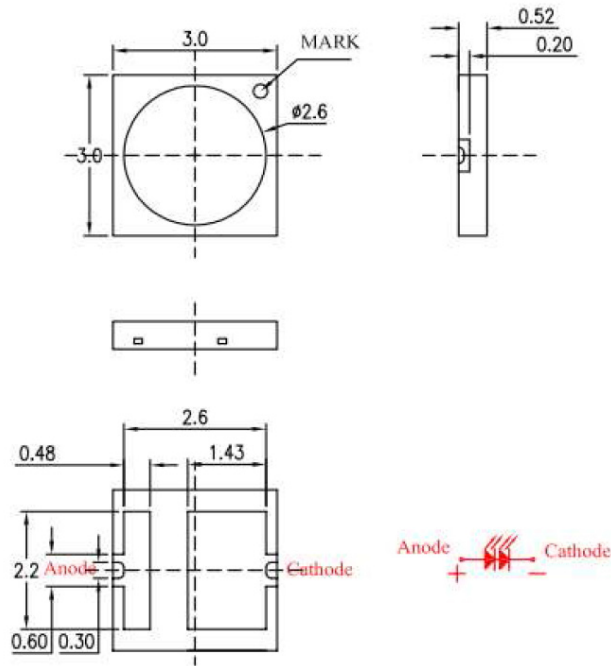

Figure 2: Mechanical Drawing for LUXEON 3030 2D. All dimensions are in millimeters.

9. T_s Measurement Point

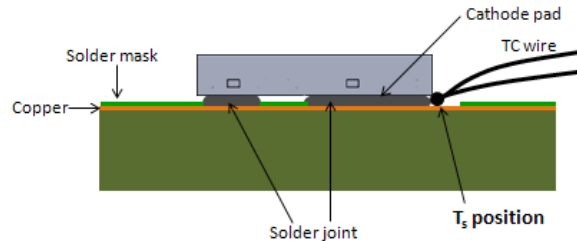

Figure 3: Preferred T_s measurement point for LUXEON 3030 2D.

For further information on measuring the in-situ T_s , please see Philips Lumileds Application Brief AB207, which is available online at www.philipslumileds.com.

10. Description of auxiliary equipment

LUXEON LED devices are soldered to reliability stress boards that can accommodate up to 25 devices and are driven by a constant current source.

Reliability stress boards are mounted in a chamber with minimal ambient airflow. The chamber temperature is controlled based on the temperature of a control T_s point, which is located on the stress board.

The reliability stress board is periodically removed from the thermal chamber, allowed to cool to room temperature, and then tested. After testing, the reliability stress board is returned to the thermal chamber for additional operation.

11. Operating Cycle

LUXEON LEDs are driven with a constant direct current (DC).

12. Ambient conditions including airflow, temperature, and relative humidity

The typical relative humidity within the chamber is < 65%. The temperature uniformity of the board (center to edge) was experimentally determined to be less than 2°C.

The photometry measurement temperature is set and monitored to be within 25°C ± 2°C with no forced airflow and RH < 65%.

13. T_s and ambient temperatures (ambient temperature measured 5mm above reliability stress board)

In all cases, both T_s and T_{air} meet or exceed the IESNA LM-80-08 limits.

14. Drive current of the LED light source during lifetime test

See tables.

15. Initial luminous flux and forward voltage at photometric measurement current

See tables.

16. Lumen maintenance for data for each individual light source along with median value, standard deviation, minimum and maximum lumen maintenance value for all of the light sources

See tables.

17. Observation of LED light source failures including the failure conditions and time of failure

No failures observed in devices reported.

18. LED light source monitoring interval

Units were tested at 0 hour and at subsequent 1,000 hours intervals.

19. Photometric measurement uncertainty

Long-term measurement uncertainty is based on reproducibility tests done over a period of one year, calculated to $k = 2$ coverage (i.e. 95% coverage).

Luminous Flux (Φ_v) ± 1.59%

Correlated Color Temperature (CCT) ± 21K

20. Chromaticity shift reported over the measurement time

See tables.

21. Sampling Method/Sample size

LED samples for IESNA LM-80 testing consist of units built from a minimum of three manufacturing lots with each manufacturing lot built from different wafer lots built on non-consecutive days. These manufacturing lots are picked to represent a wide parametric distribution.

22. ISO 17025-2005 Accreditation



International Accreditation Service
SCOPE OF ACCREDITATION

Bay Area Compliance Laboratories Corp (Dongguan) TL-460
 (Revised June 25, 2014)

Bay Area Compliance Laboratories Corp (Dongguan)
 PuLong Cun 69, Puxinhu Industrial Area
 Tangxia Town, Guang Dong 523719
 People's Republic of China

John Chan
 President
 +867 69 86858

FIELDS OF TESTING	ACCREDITED TEST METHODS
ENERGY STAR Program Requirements for Lighting (except Electromagnetic and Radio Frequency Interference, Air Tight for Restricted Air Flow, and Mercury Content)	ANSI C62.41.2-2002: IEEE Recommended Practice on Characterization of Surges in Low Voltage (1000V and Less) AC Power Circuits
	ANSI C78.5-2003: Specifications for Performance of Self-Ballasted Compact American National Standard for Fluorescent Lamps—Guide for Electrical Measurements
	ANSI C78.375-1997: Specification for the Chromaticity of Fluorescent Lamps
	ANSI C78.376-2001: Chromaticity of Solid State Lighting Products
	ANSI C78.377-2008: Specifications for the Chromaticity of Solid State Lighting Products
	ANSI C78.377-2011: Electric Lamps – Classification of the Beam Patterns of Reflector Lamps
	ANSI C78.379:2006: Metal-Halide Lamps - Method of Measuring Characteristics
	ANSI C78.387-1987: Metal-Halide Lamps - Method of Measuring Characteristics
	ANSI C78.387-2007: American National Standard for Electric Lamps – High-Intensity Discharge (HID) – Methods of Measuring Characteristics
	ANSI C78.389-2004: Fluorescent Lamp Ballasts--Methods of Measurement
	ANSI C82.2-2002: Ballast For High Intensity Discharge Lamps - Methods of Measurement
	ANSI C82.6-2005: High-Frequency Fluorescent Lamp Ballasts
	ANSI C82.11-2002: Harmonic Emission Limits – Related Power Quality Requirements for Lighting
	ANSI C82.77-2002: ANSI/IEEE C62.41 – 1991 (01-May-1991): Recommended Practice for Surge Voltages in Low-Voltage AC Power Circuits, Category A, 7 Strikes
	ANSI/UL 153-2005: Portable Electric Luminaires
	CIE Pub 13.2-1974: Method of measuring and Specifying Color Rendering of Light Sources
	CIE 13.3-1995: Method of Measuring and Specifying Color Rendering of Light Sources
	CIE 15-2004: Colorimetry Standard
	CIE 84-1989: The Measurement of Luminous Flux
	CIE 121-1996: The Photometry and Goniophotometry of Luminaires
CIE 127-1997: Measurement of LEDs	
CSA-22.2 No.37-M1989 (R2004): Christmas Tree and Other Decorative Lighting Outfits	
EPA DLS: Appendix A	
ENERGY STAR Online CBCP: Tool for Calculating Minimum Center Beam Intensity	
IEC/TR 61341: Method of measurement of centre beam intensity and beam angle(s) of reflector lamps	
IES LM-9-99: Approved Method for the Electrical and Photometric Measurements of Fluorescent Lamps	
IES LM-9-09: Approved Method for the Electrical and Photometric Measurements of Fluorescent Lamps	
IES LM-10-13: Photometric Testing of Outdoor Fluorescent Luminaires	
IES TM-16-05: Technical Memorandum on Light Emitting Diode (LED) Sources and Systems	

April 14, 2014
 Commencement Date



C. P. Ramani
 C. P. Ramani, P.E.
 President

Print Date: 06/26/2014 Page 2 of 6

This accreditation certificate supersedes any IAS accreditation certificate bearing an earlier date. The certificate becomes invalid upon suspension, cancellation or revocation of accreditation. See the IAS Accreditation Listings on the web at www.iasonline.org for current accreditation information, or contact IAS directly at (562) 364-8201.

13-08892

International Accreditation Service
SCOPE OF ACCREDITATION

Bay Area Compliance Laboratories Corp (Dongguan) TL-460
 (Revised June 25, 2014)

FIELDS OF TESTING	ACCREDITED TEST METHODS
ENERGY STAR Program Requirements for Lighting (except Electromagnetic and Radio Frequency Interference, Air Tight for Restricted Air Flow, and Mercury Content) (continued)	IES LM-16-93: Practical Guide to Colorimetry of Light Sources
	IES LM-20-13: Photometric Testing of Reflector-Type Lamps
	IES LM-31-95: Photometric Testing of Roadway Luminaires Using Incandescent Filament and HID Lamps
	IES LM-35-02: Photometric Testing of Floodlights Using High Intensity Discharge or Incandescent Filament Lamps
	IES LM-4010: Approved Method for Life Performance Testing of Fluorescent Lamps
	IES LM- 41-98: Approved Method for Photometric Testing of Indoor Fluorescent Luminaries
	IES LM-45-02: Approved Method for Electrical and Photometric Measurements of General Service Incandescent Filament Lamps
	IES LM-45-09: Approved Method for Electrical and Photometric Measurements of General Service Incandescent Filament Lamps
	IES LM-46-04: Photometric Testing of Indoor Luminaires Using High Intensity Discharge or Incandescent Filament Lamps
	IES LM-47-12: Life Testing of High Intensity Discharge (HID) Lamps
	IES LM-49-12: Life Testing of General Lighting Incandescent Filament Lamps
	IES LM-51-13: Electrical and Photometric Measurements of HID Lamps
	IES LM-54-12: IESNA Guide to Lamp Seasoning
	IES LM-58-13: Guide to Spectroradiometric Measurements
	IES LM-65-10: Approved Method for Life Testing of Single-Ended Compact Fluorescent Lamps
	IES LM-66-00: Electrical and Photometric Measurements of Single-Ended Compact Fluorescent Lamps
	IES LM-66-11: Electrical and Photometric Measurements of Single-Ended Compact Fluorescent Lamps
	ASTM G 154 – 05: Standard Practice for Operating Fluorescent Light Apparatus for UV Exposure of Nonmetallic Materials
	IES LM-79-08: Approved Method for Electrical and Photometric Measurements of Solid-State Lighting Products, Sections 9, 10 and 12
	IES LM 82-12: Characterization of LED Light Engines and LED Lamps for Electrical and Photometric Properties as a Function of Temperature
IES LM-80-08: Approved Method for Measuring Lumen Maintenance of LED Light Sources (LED Packages/Modules/Arrays)	
US EPA DLS: ENERGY STAR Program Requirements for decorative light strings Appendix A	
UL 588-2004: Standard for Seasonal and Holiday Decorative Products	
UL1993 – 2009: Self-Ballasted Lamps and Lamp Adapters	

April 14, 2014
 Commencement Date



C. P. Ramani
 C. P. Ramani, P.E.
 President

Print Date: 06/26/2014 Page 3 of 6

This accreditation certificate supersedes any IAS accreditation certificate bearing an earlier date. The certificate becomes invalid upon suspension, cancellation or revocation of accreditation. See the IAS Accreditation Listings on the web at www.iasonline.org for current accreditation information, or contact IAS directly at (562) 364-8201.

13-08892

International Accreditation Service
SCOPE OF ACCREDITATION

Bay Area Compliance Laboratories Corp (Dongguan) TL-460
 (Revised June 25, 2014)

FIELDS OF TESTING	ACCREDITED TEST METHODS
ENERGY STAR Program Requirements for Lighting (except Electromagnetic and Radio Frequency Interference, Air Tight for Restricted Air Flow, and Mercury Content) (continued)	US EPA Lamps v1 ENERGY STAR Program Requirements for Lamps (Light Bulbs), (except Sections 12,4 and 13) Elevated Temperature Life Test - ENERGY STAR Program Requirements Product Specification for Lamps Version 1.0: Elevated Temperature Life Testing Elevated Temperature Light Output Ratio- ENERGY STAR Program Requirements Product Specification for Lamps Version 1.0: Elevated Temperature Light Output Ratio Ambient Temperature Life Test Start Time Test- ENERGY STAR Program Requirements Product Specification for Lamps Version 1.0: Start Time Run Up Time Test- ENERGY STAR Program Requirements Product Specification for Lamps Version 1.0: Run-up Time 10 CFR 430 Subpart B Appendix W Uniform Test Method for Measuring the Energy Consumption of Medium Base Compact Fluorescent Lamps
ENERGY STAR Program Requirements for Electronics	Computers ENERGY STAR Program Requirements Product Specification for Computers, Version 6.0 ENERGY STAR Test Method for Computer, Rev. Oct 2013 EPRI Generalized Test Protocol for Calculating the Energy Efficiency of Internal Ac-Dc and Dc-Dc Power Supplies, Version 6.6 (for products that have internal, multi-output, or single output with integral cooling power supplies; available at: www.efficientpowersupplies.org) IEC 62301:2011 Household Electrical Appliances - Measurement of Standby Power Computer (Enterprise) Servers ENERGY STAR Test Method for Computer Servers Version 2.0, ENERGY STAR Test Procedure for Determining the Power Use of Computer Servers at Idle and Full Load (Appendix A of specification) EPRI Generalized Test Protocol for Calculating the Energy Efficiency of Internal Ac-Dc and Dc-Dc Power Supplies, Version 6.6 Available at www.efficientpowersupplies.org IEC 62301:2011 Household Electrical Appliances - Measurement of Standby Power Small Network Equipment ENERGY STAR Program Requirements for Small Network Equipment ENERGY STAR Test Procedure for Small Network Equipment Imaging Equipment ENERGY STAR Imaging Equipment Test Method Version 2.0, ENERGY STAR Program Requirements ENERGY STAR Test Method for Computer, Rev. Oct 2013 IEC 62301 Ed 1.0: Household Electrical Appliances – Measurement of Standby Power IEC 62301 Ed 2.0: Household Electrical Appliances – Measurement of Standby Power EPRI Generalized Test Protocol for Calculating the Energy Efficiency of Internal Ac-Dc and Dc-Dc Power Supplies Version 6.6. Available at www.efficientpowersupplies.org ENRGY STAR Program Requirements Product Specification for Imaging Equipment, Version 2.0 EPRI Test Method for Calculating the Energy Efficiency of Single Voltage External AC-DC and AC-AC Power Supplies, Rev. August 11, 2004, Available at www.efficientpowersupplies.org

April 14, 2014
 Commencement Date



C. P. Ramani
 C. P. Ramani, P.E.
 President

Print Date: 06/26/2014 Page 4 of 6

This accreditation certificate supersedes any IAS accreditation certificate bearing an earlier date. The certificate becomes invalid upon suspension, cancellation or revocation of accreditation. See the IAS Accreditation Listings on the web at www.iasonline.org for current accreditation information, or contact IAS directly at (562) 364-8201.

13-08892

International Accreditation Service
SCOPE OF ACCREDITATION

Bay Area Compliance Laboratories Corp (Dongguan) TL-460
 (Revised June 25, 2014)

FIELDS OF TESTING	ACCREDITED TEST METHODS
ENERGY STAR Program Requirements for Electronics (continued)	Battery Charging Systems ENERGY STAR Test Method, ENERGY STAR Program Requirements for Battery Charging Systems Version 1.1, ENERGY STAR Test Method for Battery Charging Systems, Rev. Aug 2012 IEC Standard 61951-1: Secondary cells and batteries containing alkaline or other non-acid electrolytes – Portable sealed rechargeable single cells – Part 1: Nickel-cadmium. Ed. 2.1. January 2006 IEC Standard 61951-2: Secondary cells and batteries containing alkaline or other non-acid electrolytes – Portable sealed rechargeable single cells – Part 2: Nickel-metal hydride. Ed. 2.0. April 2003 IEC Standard 61951-2: Secondary cells and batteries containing alkaline or other non-acid electrolytes – Portable sealed rechargeable single cells – Part 2: Nickel-metal hydride. Ed. 3.0. May 2011 IEC Standard 61960: Secondary cells and batteries containing alkaline or other non-acid electrolytes – Secondary lithium cells and batteries for portable applications. Ed. 1.0. December 2003 IEC Standard 61960: Secondary cells and batteries containing alkaline or other non-acid electrolytes – Secondary lithium cells and batteries for portable applications. Ed. 2.0. June 2011 Telephony ENERGY STAR Test Method for Telephony, ENERGY STAR Program Requirements for Telephony Version 3.0, (except VoIP) ENERGY STAR Test Method for Telephony, Rev. Nov. 2013 Set Top Boxes ENERGY STAR Test Method for Set-top Boxes Version 3.0 (Testing Products for ENERGY STAR) ENERGY STAR Program Requirements for Set-top Boxes Version 3.0 Televisions ENERGY STAR Program Requirements Product Specification for Televisions Eligibility Criteria Version 6.1 10 CFR 430 Subpart B Appendix H Uniform Test Method for Measuring the Power Consumption of Television Sets 10 CFR 429.25 Subpart B Television Sets 77FR 2864 NOPR Test Procedure for Television sets ENERGY STAR Test Method for Televisions, Rev. Aug 2010 Displays ENERGY STAR® Program Requirements Product Specification for Displays Eligibility Criteria Version 6.0 ENERGY STAR Test Method for Determining Displays Energy use Version 6.0, Rev. Jan. 2013 Audio/Video ENERGY STAR Program Requirements for Audio/Video ENERGY STAR Test Procedure for Audio/Video product
ENERGY STAR Program Requirements for Appliances	Water Coolers ENERGY STAR Program Requirements Product Specification for Water Coolers Version 2.0, ENERGY STAR Test Method for Water Coolers, Rev. May 2013
Safety Testing for UV Exposure	IEC 62471:2006/EN 62471:2008: Photobiological Safety of Lamps and Lamp Systems

April 14, 2014
 Commencement Date



C. P. Ramani
 C. P. Ramani, P.E.
 President

Print Date: 06/26/2014 Page 5 of 6

This accreditation certificate supersedes any IAS accreditation certificate bearing an earlier date. The certificate becomes invalid upon suspension, cancellation or revocation of accreditation. See the IAS Accreditation Listings on the web at www.iasonline.org for current accreditation information, or contact IAS directly at (562) 364-8201.

13-08892

International Accreditation Service
SCOPE OF ACCREDITATION

Bay Area Compliance Laboratories Corp (Dongguan) TL-460
 (Revised June 25, 2014)

FIELDS OF TESTING	ACCREDITED TEST METHODS
Safety Testing	IEC 62031 Edition 2.0: LED Modules for General Lighting – Safety Specifications ANSI/UL 1598: 2008: Luminaires ANSI/UL 1574:2004: Standard for Track Lighting Systems ASTM G154:2006: Standard Practice for Operating Fluorescent Light Apparatus for UV Exposure of Nonmetallic Materials UL153-2005: Portable Luminaires
Energy Efficiency	IEC 62623:2012-10 Edition 1.0: Desktop and Notebook Computers – Measurement of Energy Consumption IEC 62612:2013: Self-ballasted LED lamps for general lighting services with supply voltage >50v – Performance requirements IEC 62087 Ed. 3.0 -2011-04: Methods of measurement for the power consumption of audio, video and related equipment EN/IEC 60969 Ed. 1.2:2001: Self-Ballasted Lamps for General Lighting Services - Performance Requirements

April 14, 2014
 Commencement Date



C. P. Ramani
 C. P. Ramani, P.E.
 President

Print Date: 06/26/2014

Page 6 of 6

This accreditation certificate supersedes any IAS accreditation certificate bearing an earlier date. The certificate becomes invalid upon suspension, cancellation or revocation of accreditation. See the IAS Accreditation Listings on the web at www.iasonline.org for current accreditation information, or contact IAS directly at (562) 364-8201.

13-08892

Notes

Data is for reference only and is not an endorsement to exceed the Data Sheet operating conditions.

The TM-21 extrapolations are based on IES TM-21-11 "Projecting Long Term Lumen Maintenance of LED Light Sources. The TM-21 lumen maintenance model is based on the flux data normalized to 1 at 0 hours and the use of an exponential model for flux(time):

$\text{Flux}(\text{time}) = B \exp[-\alpha \cdot \text{time}]$, where normally $B \cong 1$, and $\alpha > 0$.

An L70 extrapolation less than 0 means that the model predicts an increasing flux output with time, i.e. $\alpha < 0$ (see graphs). Generally, this means that additional test time is needed to determine the long-term lumen maintenance behavior.

Disclaimer

Although PHILIPS LUMILEDS LIGHTING COMPANY has attempted to provide the most accurate information and materials and services data (hereinafter "Data"), the Data is provided "as is" and may contain errors. The entire risk of use of the data shall be with the user. PHILIPS LUMILEDS LIGHTING COMPANY makes no warranty, express or implied, including, but not limited to, the implied warranties of merchantability and fitness for a particular purpose, regarding the contents or correctness of the Data provided or the ability of the Data to meet the user's needs or expectations. PHILIPS LUMILEDS LIGHTING COMPANY reserves the right to make changes without notice. You as user agree to this disclaimer and user agreement with the download or use of the provided materials and Data.

In no event shall PHILIPS LUMILEDS LIGHTING COMPANY be liable for any direct, indirect, special, incidental, exemplary, or consequential damages arising out of or related to the use of the Data, however caused, regardless of theory of liability, and whether or not PHILIPS LUMILEDS LIGHTING COMPANY has been advised of the possibility of such damage. This limitation shall apply notwithstanding any failure of essential purpose or any exclusive remedy.

Normalized Flux Statistics for $I_f = 165\text{mA}$

	0hrs	1000hrs	2000hrs	3000hrs	4000hrs	5000hrs	6000hrs	7000hrs	8000hrs	9000hrs	alpha	B	L70	
Ts=Tair=105°C	median =	1.0000	0.9884	0.9822	0.9773	0.9660	0.9629	0.9581	0.9541	0.9510	0.9435			
	average =	1.0000	0.9891	0.9815	0.9768	0.9674	0.9627	0.9573	0.9536	0.9525	0.9456	4.2712e-06	0.9834	79,596
	st dev =	0.0000	0.0046	0.0051	0.0047	0.0050	0.0049	0.0050	0.0051	0.0064	0.0069	TM-21 L70(9k) > 54,000hrs		
	min =	1.0000	0.9807	0.9745	0.9701	0.9590	0.9560	0.9491	0.9446	0.9436	0.9330			
	max =	1.0000	0.9973	0.9911	0.9845	0.9776	0.9733	0.9701	0.9664	0.9673	0.9596			
Ts=Tair=85°C	median =	1.0000	0.9905	0.9866	0.9803	0.9731	0.9666	0.9608	0.9582	0.9561	0.9513			
	average =	1.0000	0.9897	0.9843	0.9801	0.9728	0.9671	0.9624	0.9577	0.9566	0.9519	4.1795e-06	0.9879	82,416
	st dev =	0.0000	0.0056	0.0061	0.0061	0.0062	0.0059	0.0061	0.0061	0.0060	0.0060	TM-21 L70(9k) > 54,000hrs		
	min =	1.0000	0.9801	0.9749	0.9702	0.9614	0.9579	0.9529	0.9483	0.9448	0.9395			
	max =	1.0000	0.9973	0.9937	0.9928	0.9848	0.9778	0.9750	0.9707	0.9742	0.9682			
Ts=Tair=55°C	median =	1.0000	0.9938	0.9877	0.9845	0.9785	0.9733	0.9696	0.9647	0.9599	0.9570			
	average =	1.0000	0.9926	0.9864	0.9836	0.9769	0.9725	0.9681	0.9634	0.9584	0.9549	4.6545e-06	0.9953	75,623
	st dev =	0.0000	0.0044	0.0049	0.0049	0.0055	0.0055	0.0055	0.0061	0.0067	0.0068	TM-21 L70(9k) > 54,000hrs		
	min =	1.0000	0.9839	0.9756	0.9729	0.9648	0.9621	0.9558	0.9493	0.9440	0.9413			
	max =	1.0000	0.9991	0.9964	0.9937	0.9865	0.9819	0.9792	0.9747	0.9682	0.9647			

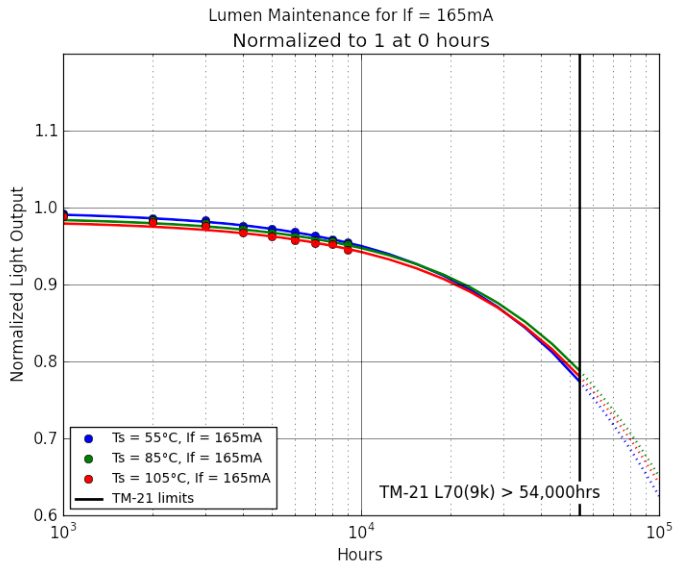

Delta u'v' for $I_f = 165\text{mA}$

	0hrs	1000hrs	2000hrs	3000hrs	4000hrs	5000hrs	6000hrs	7000hrs	8000hrs	9000hrs	
Ts=Tair=105°C	median =	0.0000	0.0014	0.0019	0.0022	0.0025	0.0029	0.0035	0.0040	0.0043	0.0048
	average =	0.0000	0.0014	0.0019	0.0023	0.0026	0.0029	0.0036	0.0040	0.0044	0.0048
	st dev =	0.0000	0.0003	0.0003	0.0003	0.0003	0.0003	0.0004	0.0004	0.0006	0.0005
	min =	0.0000	0.0010	0.0013	0.0017	0.0021	0.0023	0.0030	0.0031	0.0028	0.0035
	max =	0.0000	0.0020	0.0028	0.0031	0.0033	0.0036	0.0044	0.0048	0.0056	0.0059
Ts=Tair=85°C	median =	0.0000	0.0013	0.0019	0.0023	0.0026	0.0029	0.0033	0.0037	0.0040	0.0045
	average =	0.0000	0.0013	0.0019	0.0023	0.0025	0.0028	0.0033	0.0038	0.0043	0.0048
	st dev =	0.0000	0.0003	0.0004	0.0004	0.0004	0.0004	0.0005	0.0005	0.0006	0.0007
	min =	0.0000	0.0009	0.0013	0.0016	0.0018	0.0020	0.0026	0.0029	0.0034	0.0038
	max =	0.0000	0.0023	0.0028	0.0030	0.0032	0.0035	0.0049	0.0052	0.0056	0.0065
Ts=Tair=55°C	median =	0.0000	0.0011	0.0016	0.0019	0.0021	0.0023	0.0027	0.0032	0.0037	0.0040
	average =	0.0000	0.0012	0.0017	0.0019	0.0021	0.0024	0.0029	0.0033	0.0038	0.0042
	st dev =	0.0000	0.0004	0.0003	0.0004	0.0004	0.0004	0.0004	0.0005	0.0005	0.0006
	min =	0.0000	0.0008	0.0012	0.0014	0.0017	0.0019	0.0023	0.0023	0.0029	0.0033
	max =	0.0000	0.0024	0.0025	0.0027	0.0029	0.0033	0.0043	0.0047	0.0054	0.0056

Normalized Flux Statistics for $I_f = 200\text{mA}$

	0hrs	1000hrs	2000hrs	3000hrs	4000hrs	5000hrs	6000hrs	7000hrs	8000hrs	9000hrs	alpha	B	L70	
Ts=Tair=105°C	median =	1.0000	0.9919	0.9810	0.9763	0.9686	0.9631	0.9571	0.9533	0.9438	0.9345			
	average =	1.0000	0.9914	0.9810	0.9755	0.9688	0.9629	0.9567	0.9524	0.9434	0.9347	7.0063e-06	0.9975	50,549
	st dev =	0.0000	0.0045	0.0048	0.0053	0.0054	0.0057	0.0054	0.0054	0.0056	0.0054	TM-21 L70(9k) = 51,000hrs		
	min =	1.0000	0.9774	0.9702	0.9656	0.9586	0.9507	0.9445	0.9396	0.9297	0.9221			
	max =	1.0000	0.9977	0.9889	0.9838	0.9786	0.9734	0.9653	0.9607	0.9517	0.9435			
Ts=Tair=85°C	median =	1.0000	0.9933	0.9864	0.9809	0.9737	0.9691	0.9632	0.9591	0.9534	0.9455			
	average =	1.0000	0.9932	0.9870	0.9804	0.9739	0.9682	0.9636	0.9595	0.9527	0.9452	5.7725e-06	0.9972	61,304
	st dev =	0.0000	0.0041	0.0051	0.0043	0.0049	0.0047	0.0051	0.0051	0.0062	0.0062	TM-21 L70(9k) > 54,000hrs		
	min =	1.0000	0.9825	0.9769	0.9722	0.9642	0.9586	0.9531	0.9491	0.9411	0.9324			
	max =	1.0000	1.0015	0.9985	0.9892	0.9830	0.9769	0.9722	0.9684	0.9622	0.9559			
Ts=Tair=55°C	median =	1.0000	0.9932	0.9867	0.9818	0.9771	0.9726	0.9692	0.9657	0.9599	0.9540			
	average =	1.0000	0.9936	0.9872	0.9828	0.9775	0.9734	0.9693	0.9650	0.9597	0.9547	4.7110e-06	0.9966	74,993
	st dev =	0.0000	0.0028	0.0029	0.0038	0.0045	0.0042	0.0047	0.0064	0.0070	0.0069	TM-21 L70(9k) > 54,000hrs		
	min =	1.0000	0.9873	0.9806	0.9759	0.9704	0.9658	0.9603	0.9428	0.9374	0.9327			
	max =	1.0000	0.9992	0.9932	0.9924	0.9886	0.9833	0.9803	0.9765	0.9719	0.9666			

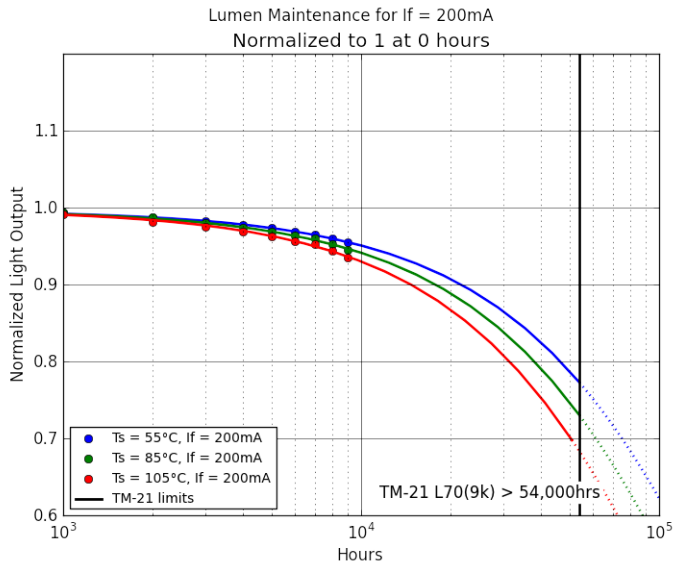

Delta u'v' for $I_f = 200\text{mA}$

	0hrs	1000hrs	2000hrs	3000hrs	4000hrs	5000hrs	6000hrs	7000hrs	8000hrs	9000hrs	
Ts=Tair=105°C	median =	0.0000	0.0016	0.0020	0.0022	0.0025	0.0029	0.0033	0.0037	0.0041	0.0047
	average =	0.0000	0.0017	0.0020	0.0022	0.0026	0.0030	0.0033	0.0037	0.0041	0.0046
	st dev =	0.0000	0.0002	0.0003	0.0003	0.0003	0.0003	0.0003	0.0003	0.0004	0.0005
	min =	0.0000	0.0014	0.0017	0.0018	0.0022	0.0025	0.0028	0.0033	0.0034	0.0038
	max =	0.0000	0.0025	0.0031	0.0032	0.0036	0.0039	0.0039	0.0044	0.0052	0.0055
Ts=Tair=85°C	median =	0.0000	0.0015	0.0017	0.0020	0.0025	0.0027	0.0030	0.0034	0.0041	0.0047
	average =	0.0000	0.0015	0.0017	0.0021	0.0024	0.0027	0.0030	0.0035	0.0041	0.0046
	st dev =	0.0000	0.0002	0.0002	0.0003	0.0003	0.0003	0.0003	0.0003	0.0004	0.0004
	min =	0.0000	0.0012	0.0014	0.0015	0.0019	0.0021	0.0025	0.0028	0.0033	0.0038
	max =	0.0000	0.0020	0.0022	0.0026	0.0029	0.0032	0.0035	0.0041	0.0048	0.0055
Ts=Tair=55°C	median =	0.0000	0.0014	0.0017	0.0018	0.0021	0.0024	0.0028	0.0031	0.0035	0.0039
	average =	0.0000	0.0015	0.0017	0.0019	0.0022	0.0024	0.0028	0.0032	0.0036	0.0040
	st dev =	0.0000	0.0002	0.0002	0.0002	0.0002	0.0002	0.0003	0.0003	0.0006	0.0006
	min =	0.0000	0.0011	0.0015	0.0016	0.0019	0.0022	0.0021	0.0024	0.0025	0.0030
	max =	0.0000	0.0017	0.0021	0.0023	0.0025	0.0028	0.0036	0.0041	0.0051	0.0057

Luminous Flux [lm] data for tested units

$T_s = T_{air} = 55^{\circ}\text{C}$, $I_f = 165\text{mA}$; $T_s \geq 53^{\circ}\text{C}$ and $T_{air} \geq 50^{\circ}\text{C}$ in compliance with LM-80-08

	CCT (t=0)	0hrs	1000hrs	2000hrs	3000hrs	4000hrs	5000hrs	6000hrs	7000hrs	8000hrs	9000hrs
1	2851K	111.900	111.300	110.500	110.400	109.700	109.200	108.800	108.400	107.400	106.900
2	2858K	116.300	114.600	114.300	114.100	113.100	112.600	112.300	111.900	111.200	110.800
3	2848K	115.900	114.100	113.700	113.200	112.600	112.100	111.600	111.200	110.300	109.900
4	2863K	112.200	111.500	110.700	110.600	108.700	108.000	107.700	107.000	106.500	106.100
5	2859K	111.600	111.400	110.500	110.400	109.600	109.000	108.300	107.800	107.700	107.200
6	2835K	110.800	110.700	110.400	110.100	109.300	108.800	108.500	108.000	106.700	106.400
7	2852K	116.100	115.200	114.600	114.400	113.600	113.000	112.400	112.000	112.200	111.900
8	2862K	113.300	112.400	112.200	111.900	111.100	110.400	110.200	109.700	108.800	108.500
9	2859K	114.900	113.800	113.000	112.700	112.000	111.400	110.900	110.500	110.200	110.000
10	2842K	115.600	114.900	114.200	113.800	113.100	112.400	111.900	111.400	110.100	109.700
11	2829K	110.500	110.000	109.600	109.000	108.300	107.700	106.900	106.600	105.900	105.500
12	2858K	112.100	110.300	109.500	109.400	108.600	108.200	107.700	107.300	106.700	106.200
13	2808K	116.200	115.800	115.300	114.900	114.300	113.900	113.200	112.700	112.500	112.100
14	2864K	109.600	109.300	108.400	108.000	107.300	106.900	106.500	105.900	105.200	104.700
15	2809K	112.300	112.000	111.100	110.500	109.900	109.600	109.000	108.500	107.400	107.100
16	2841K	114.500	113.500	112.400	111.800	111.000	110.400	109.700	108.700	108.400	108.000
17	2866K	116.300	115.700	114.900	114.500	113.800	113.100	112.500	112.000	111.700	111.500
18	2821K	113.500	113.100	112.100	111.600	110.800	110.400	110.100	109.500	109.500	108.900
19	2773K	110.800	109.900	108.100	107.800	106.900	106.600	105.900	105.200	104.600	104.300
20	2774K	111.900	110.400	109.800	109.600	109.000	108.900	108.500	108.100	107.800	107.400
21	2762K	110.800	109.200	108.600	108.300	107.600	107.200	107.000	106.400	105.100	104.500
22	2764K	113.000	111.900	111.300	111.200	110.600	110.100	109.800	109.400	109.300	108.900
23	2731K	109.600	109.000	108.400	108.100	107.500	107.000	106.400	105.900	105.600	105.200
24	2722K	109.300	108.500	108.100	108.000	107.500	107.100	106.000	104.900	105.200	104.800
25	2741K	111.500	111.000	110.300	110.000	109.300	109.000	108.800	108.200	107.100	106.700

Normalized Luminous Flux data for tested units

$T_s = T_{air} = 55^{\circ}\text{C}$, $I_f = 165\text{mA}$; $T_s \geq 53^{\circ}\text{C}$ and $T_{air} \geq 50^{\circ}\text{C}$ in compliance with LM-80-08

	CCT (t=0)	0hrs	1000hrs	2000hrs	3000hrs	4000hrs	5000hrs	6000hrs	7000hrs	8000hrs	9000hrs
1	2851K	1.0000	0.9946	0.9875	0.9866	0.9803	0.9759	0.9723	0.9687	0.9598	0.9553
2	2858K	1.0000	0.9854	0.9828	0.9811	0.9725	0.9682	0.9656	0.9622	0.9561	0.9527
3	2848K	1.0000	0.9845	0.9810	0.9767	0.9715	0.9672	0.9629	0.9594	0.9517	0.9482
4	2863K	1.0000	0.9938	0.9866	0.9857	0.9688	0.9626	0.9599	0.9537	0.9492	0.9456
5	2859K	1.0000	0.9982	0.9901	0.9892	0.9821	0.9767	0.9704	0.9659	0.9651	0.9606
6	2835K	1.0000	0.9991	0.9964	0.9937	0.9865	0.9819	0.9792	0.9747	0.9630	0.9603
7	2852K	1.0000	0.9922	0.9871	0.9854	0.9785	0.9733	0.9681	0.9647	0.9664	0.9638
8	2862K	1.0000	0.9921	0.9903	0.9876	0.9806	0.9744	0.9726	0.9682	0.9603	0.9576
9	2859K	1.0000	0.9904	0.9835	0.9809	0.9748	0.9695	0.9652	0.9617	0.9591	0.9574
10	2842K	1.0000	0.9939	0.9879	0.9844	0.9784	0.9723	0.9680	0.9637	0.9524	0.9490
11	2829K	1.0000	0.9955	0.9919	0.9864	0.9801	0.9747	0.9674	0.9647	0.9584	0.9548
12	2858K	1.0000	0.9839	0.9768	0.9759	0.9688	0.9652	0.9607	0.9572	0.9518	0.9474
13	2808K	1.0000	0.9966	0.9923	0.9888	0.9836	0.9802	0.9742	0.9699	0.9682	0.9647
14	2864K	1.0000	0.9973	0.9891	0.9854	0.9790	0.9754	0.9717	0.9662	0.9599	0.9553
15	2809K	1.0000	0.9973	0.9893	0.9840	0.9786	0.9760	0.9706	0.9662	0.9564	0.9537
16	2841K	1.0000	0.9913	0.9817	0.9764	0.9694	0.9642	0.9581	0.9493	0.9467	0.9432
17	2866K	1.0000	0.9948	0.9880	0.9845	0.9785	0.9725	0.9673	0.9630	0.9604	0.9587
18	2821K	1.0000	0.9965	0.9877	0.9833	0.9762	0.9727	0.9700	0.9648	0.9648	0.9595
19	2773K	1.0000	0.9919	0.9756	0.9729	0.9648	0.9621	0.9558	0.9495	0.9440	0.9413
20	2774K	1.0000	0.9866	0.9812	0.9794	0.9741	0.9732	0.9696	0.9660	0.9634	0.9598
21	2762K	1.0000	0.9856	0.9801	0.9774	0.9711	0.9675	0.9657	0.9603	0.9486	0.9431
22	2764K	1.0000	0.9903	0.9850	0.9841	0.9788	0.9743	0.9717	0.9681	0.9673	0.9637
23	2731K	1.0000	0.9945	0.9891	0.9863	0.9808	0.9763	0.9708	0.9662	0.9635	0.9599
24	2722K	1.0000	0.9927	0.9890	0.9881	0.9835	0.9799	0.9698	0.9597	0.9625	0.9588
25	2741K	1.0000	0.9955	0.9892	0.9865	0.9803	0.9776	0.9758	0.9704	0.9605	0.9570

TM-21 Extrapolation of Luminous Flux data for tested units

$T_s = T_{air} = 55^{\circ}\text{C}$, $I_f = 165\text{mA}$; $T_s \geq 53^{\circ}\text{C}$ and $T_{air} \geq 50^{\circ}\text{C}$ in compliance with LM-80-08

	CCT (t=0)	alpha	B	L70
1	2851K	5.2235e-06	1.0021	68,691
2	2858K	4.1094e-06	0.9889	84,084
3	2848K	4.9573e-06	0.9916	70,242
4	2863K	4.8437e-06	0.9872	70,975
5	2859K	4.3237e-06	0.9978	81,974
6	2835K	5.6441e-06	1.0106	65,069
7	2852K	2.8648e-06	0.9873	120,053
8	2862K	4.7642e-06	0.9994	74,741
9	2859K	3.6056e-06	0.9875	95,422
10	2842K	6.2605e-06	1.0039	57,599
11	2829K	5.2670e-06	1.0003	67,775
12	2858K	4.4954e-06	0.9869	76,412
13	2808K	3.9630e-06	0.9988	89,709
14	2864K	5.0397e-06	1.0001	70,795
15	2809K	5.5562e-06	1.0024	64,628
16	2841K	5.7428e-06	0.9914	60,612
17	2866K	4.1117e-06	0.9929	85,016
18	2821K	3.3287e-06	0.9891	103,872
19	2773K	5.3304e-06	0.9865	64,358
20	2774K	3.0883e-06	0.9873	111,351
21	2762K	6.0327e-06	0.9977	58,742
22	2764K	2.9422e-06	0.9894	117,597
23	2731K	4.3531e-06	0.9974	81,334
24	2722K	5.4662e-06	1.0040	65,990
25	2741K	5.1046e-06	1.0029	70,450
ave	2819K	4.6545e-06	0.9953	75,623

CIE 1976 u' data for tested units

$T_s = T_{air} = 55^{\circ}\text{C}$, $I_f = 165\text{mA}$; $T_s \geq 53^{\circ}\text{C}$ and $T_{air} \geq 50^{\circ}\text{C}$ in compliance with LM-80-08

	CCT (t=0)	0hrs	1000hrs	2000hrs	3000hrs	4000hrs	5000hrs	6000hrs	7000hrs	8000hrs	9000hrs
1	2851K	0.2544	0.2527	0.2525	0.2529	0.2529	0.2527	0.2522	0.2518	0.2516	0.2516
2	2858K	0.2545	0.2529	0.2521	0.2520	0.2518	0.2516	0.2515	0.2513	0.2513	0.2515
3	2848K	0.2544	0.2532	0.2524	0.2526	0.2525	0.2521	0.2520	0.2517	0.2517	0.2516
4	2863K	0.2539	0.2526	0.2520	0.2517	0.2516	0.2511	0.2509	0.2507	0.2503	0.2502
5	2859K	0.2546	0.2537	0.2530	0.2527	0.2525	0.2524	0.2519	0.2514	0.2508	0.2506
6	2835K	0.2551	0.2539	0.2534	0.2530	0.2527	0.2525	0.2525	0.2521	0.2517	0.2511
7	2852K	0.2552	0.2543	0.2538	0.2537	0.2533	0.2531	0.2529	0.2525	0.2519	0.2515
8	2862K	0.2547	0.2530	0.2527	0.2527	0.2526	0.2524	0.2521	0.2517	0.2512	0.2505
9	2859K	0.2546	0.2537	0.2532	0.2532	0.2530	0.2528	0.2523	0.2522	0.2521	0.2519
10	2842K	0.2552	0.2543	0.2538	0.2540	0.2538	0.2536	0.2530	0.2528	0.2519	0.2515
11	2829K	0.2553	0.2543	0.2538	0.2535	0.2532	0.2530	0.2524	0.2522	0.2523	0.2521
12	2858K	0.2545	0.2536	0.2531	0.2532	0.2530	0.2528	0.2525	0.2518	0.2518	0.2515
13	2808K	0.2562	0.2551	0.2545	0.2545	0.2544	0.2542	0.2537	0.2535	0.2536	0.2536
14	2864K	0.2548	0.2535	0.2529	0.2529	0.2528	0.2527	0.2520	0.2518	0.2519	0.2519
15	2809K	0.2560	0.2552	0.2547	0.2546	0.2545	0.2544	0.2537	0.2536	0.2534	0.2532
16	2841K	0.2548	0.2539	0.2536	0.2536	0.2533	0.2532	0.2526	0.2520	0.2521	0.2521
17	2866K	0.2540	0.2525	0.2522	0.2522	0.2521	0.2519	0.2512	0.2510	0.2509	0.2509
18	2821K	0.2557	0.2545	0.2542	0.2541	0.2540	0.2538	0.2534	0.2531	0.2529	0.2528
19	2773K	0.2577	0.2554	0.2554	0.2562	0.2559	0.2557	0.2539	0.2535	0.2531	0.2530
20	2774K	0.2588	0.2579	0.2573	0.2578	0.2576	0.2574	0.2567	0.2563	0.2555	0.2554
21	2762K	0.2591	0.2584	0.2578	0.2576	0.2575	0.2573	0.2569	0.2566	0.2563	0.2561
22	2764K	0.2590	0.2583	0.2577	0.2578	0.2577	0.2576	0.2572	0.2568	0.2564	0.2562
23	2731K	0.2608	0.2597	0.2592	0.2592	0.2591	0.2592	0.2588	0.2585	0.2580	0.2577
24	2722K	0.2608	0.2599	0.2595	0.2611	0.2609	0.2607	0.2603	0.2598	0.2592	0.2583
25	2741K	0.2597	0.2588	0.2582	0.2581	0.2581	0.2579	0.2575	0.2573	0.2572	0.2568

CIE 1976 v' data for tested units

$T_s = T_{air} = 55^{\circ}\text{C}$, $I_f = 165\text{mA}$; $T_s \geq 53^{\circ}\text{C}$ and $T_{air} \geq 50^{\circ}\text{C}$ in compliance with LM-80-08

	CCT (t=0)	0hrs	1000hrs	2000hrs	3000hrs	4000hrs	5000hrs	6000hrs	7000hrs	8000hrs	9000hrs
1	2851K	0.5322	0.5317	0.5319	0.5310	0.5308	0.5306	0.5306	0.5302	0.5298	0.5297
2	2858K	0.5304	0.5298	0.5298	0.5294	0.5294	0.5291	0.5287	0.5282	0.5276	0.5274
3	2848K	0.5331	0.5328	0.5327	0.5323	0.5321	0.5321	0.5317	0.5312	0.5306	0.5303
4	2863K	0.5318	0.5313	0.5313	0.5308	0.5306	0.5305	0.5301	0.5297	0.5291	0.5286
5	2859K	0.5297	0.5294	0.5293	0.5288	0.5286	0.5284	0.5282	0.5278	0.5272	0.5265
6	2835K	0.5324	0.5321	0.5320	0.5315	0.5313	0.5311	0.5309	0.5306	0.5301	0.5295
7	2852K	0.5285	0.5281	0.5282	0.5277	0.5276	0.5274	0.5271	0.5267	0.5262	0.5254
8	2862K	0.5288	0.5280	0.5281	0.5276	0.5274	0.5271	0.5270	0.5268	0.5264	0.5259
9	2859K	0.5296	0.5294	0.5293	0.5289	0.5286	0.5284	0.5282	0.5278	0.5275	0.5275
10	2842K	0.5302	0.5299	0.5299	0.5293	0.5290	0.5287	0.5285	0.5284	0.5278	0.5275
11	2829K	0.5325	0.5322	0.5322	0.5315	0.5314	0.5312	0.5310	0.5306	0.5304	0.5303
12	2858K	0.5305	0.5302	0.5303	0.5299	0.5298	0.5296	0.5292	0.5287	0.5284	0.5283
13	2808K	0.5332	0.5330	0.5331	0.5326	0.5323	0.5321	0.5319	0.5316	0.5314	0.5312
14	2864K	0.5278	0.5272	0.5273	0.5268	0.5265	0.5263	0.5262	0.5257	0.5254	0.5251
15	2809K	0.5335	0.5333	0.5333	0.5328	0.5326	0.5323	0.5322	0.5318	0.5315	0.5312
16	2841K	0.5325	0.5322	0.5323	0.5318	0.5316	0.5313	0.5312	0.5306	0.5303	0.5301
17	2866K	0.5310	0.5305	0.5306	0.5301	0.5299	0.5296	0.5294	0.5290	0.5286	0.5283
18	2821K	0.5324	0.5322	0.5322	0.5318	0.5316	0.5312	0.5312	0.5307	0.5304	0.5301
19	2773K	0.5338	0.5330	0.5332	0.5318	0.5315	0.5312	0.5318	0.5316	0.5310	0.5308
20	2774K	0.5282	0.5275	0.5276	0.5267	0.5265	0.5263	0.5265	0.5264	0.5258	0.5253
21	2762K	0.5293	0.5287	0.5288	0.5284	0.5281	0.5279	0.5278	0.5275	0.5272	0.5266
22	2764K	0.5297	0.5292	0.5293	0.5289	0.5286	0.5284	0.5283	0.5280	0.5277	0.5271
23	2731K	0.5283	0.5276	0.5277	0.5272	0.5270	0.5268	0.5267	0.5264	0.5261	0.5254
24	2722K	0.5303	0.5298	0.5299	0.5289	0.5286	0.5284	0.5281	0.5282	0.5279	0.5275
25	2741K	0.5313	0.5308	0.5307	0.5302	0.5300	0.5298	0.5297	0.5294	0.5291	0.5289

Delta u'v' data for tested units

$T_s = T_{air} = 55^{\circ}\text{C}$, $I_f = 165\text{mA}$; $T_s \geq 53^{\circ}\text{C}$ and $T_{air} \geq 50^{\circ}\text{C}$ in compliance with LM-80-08

	CCT (t=0)	0hrs	1000hrs	2000hrs	3000hrs	4000hrs	5000hrs	6000hrs	7000hrs	8000hrs	9000hrs
1	2851K	0.0000	0.0018	0.0019	0.0019	0.0021	0.0023	0.0027	0.0033	0.0037	0.0038
2	2858K	0.0000	0.0017	0.0025	0.0027	0.0029	0.0032	0.0034	0.0039	0.0043	0.0042
3	2848K	0.0000	0.0012	0.0020	0.0020	0.0021	0.0025	0.0028	0.0033	0.0037	0.0040
4	2863K	0.0000	0.0014	0.0020	0.0024	0.0026	0.0031	0.0034	0.0038	0.0045	0.0049
5	2859K	0.0000	0.0009	0.0016	0.0021	0.0024	0.0026	0.0031	0.0037	0.0045	0.0051
6	2835K	0.0000	0.0012	0.0017	0.0023	0.0026	0.0029	0.0030	0.0035	0.0041	0.0049
7	2852K	0.0000	0.0010	0.0014	0.0017	0.0021	0.0024	0.0027	0.0032	0.0040	0.0048
8	2862K	0.0000	0.0019	0.0021	0.0023	0.0025	0.0029	0.0032	0.0036	0.0042	0.0051
9	2859K	0.0000	0.0009	0.0014	0.0016	0.0019	0.0022	0.0027	0.0030	0.0033	0.0034
10	2842K	0.0000	0.0009	0.0014	0.0015	0.0018	0.0022	0.0028	0.0030	0.0041	0.0046
11	2829K	0.0000	0.0010	0.0015	0.0021	0.0024	0.0026	0.0033	0.0036	0.0037	0.0039
12	2858K	0.0000	0.0009	0.0014	0.0014	0.0017	0.0019	0.0024	0.0032	0.0034	0.0037
13	2808K	0.0000	0.0011	0.0017	0.0018	0.0020	0.0023	0.0028	0.0031	0.0032	0.0033
14	2864K	0.0000	0.0014	0.0020	0.0021	0.0024	0.0026	0.0032	0.0037	0.0038	0.0040
15	2809K	0.0000	0.0008	0.0013	0.0016	0.0017	0.0020	0.0026	0.0029	0.0033	0.0036
16	2841K	0.0000	0.0009	0.0012	0.0014	0.0017	0.0020	0.0026	0.0034	0.0035	0.0036
17	2866K	0.0000	0.0016	0.0018	0.0020	0.0022	0.0025	0.0032	0.0036	0.0039	0.0041
18	2821K	0.0000	0.0012	0.0015	0.0017	0.0019	0.0022	0.0026	0.0031	0.0034	0.0037
19	2773K	0.0000	0.0024	0.0024	0.0025	0.0029	0.0033	0.0043	0.0047	0.0054	0.0056
20	2774K	0.0000	0.0011	0.0016	0.0018	0.0021	0.0024	0.0027	0.0031	0.0041	0.0045
21	2762K	0.0000	0.0009	0.0014	0.0017	0.0020	0.0023	0.0027	0.0031	0.0035	0.0040
22	2764K	0.0000	0.0009	0.0014	0.0014	0.0017	0.0019	0.0023	0.0028	0.0033	0.0038
23	2731K	0.0000	0.0013	0.0017	0.0019	0.0021	0.0022	0.0026	0.0030	0.0036	0.0042
24	2722K	0.0000	0.0010	0.0014	0.0014	0.0017	0.0019	0.0023	0.0023	0.0029	0.0038
25	2741K	0.0000	0.0010	0.0016	0.0019	0.0021	0.0023	0.0027	0.0031	0.0033	0.0038

Forward Voltage [V] data for tested units

$T_s = T_{air} = 55^{\circ}\text{C}$, $I_f = 165\text{mA}$; $T_s \geq 53^{\circ}\text{C}$ and $T_{air} \geq 50^{\circ}\text{C}$ in compliance with LM-80-08

	CCT (t=0)	0hrs	1000hrs	2000hrs	3000hrs	4000hrs	5000hrs	6000hrs	7000hrs	8000hrs	9000hrs
1	2851K	6.267	6.229	6.229	6.224	6.221	6.228	6.226	6.237	6.231	6.298
2	2858K	6.143	6.116	6.115	6.110	6.108	6.114	6.113	6.121	6.117	6.116
3	2848K	6.269	6.237	6.243	6.237	6.233	6.242	6.239	6.252	6.244	6.244
4	2863K	6.112	6.105	6.100	6.100	6.102	6.102	6.106	6.111	6.106	6.124
5	2859K	6.247	6.221	6.226	6.221	6.218	6.228	6.227	6.234	6.229	6.226
6	2835K	6.322	6.296	6.304	6.305	6.303	6.309	6.310	6.316	6.315	6.310
7	2852K	6.170	6.139	6.143	6.137	6.136	6.144	6.141	6.148	6.146	6.144
8	2862K	6.295	6.261	6.265	6.263	6.261	6.265	6.266	6.278	6.266	6.271
9	2859K	6.254	6.227	6.225	6.227	6.231	6.230	6.229	6.242	6.237	6.229
10	2842K	6.061	6.049	6.053	6.045	6.046	6.049	6.051	6.061	6.051	6.049
11	2829K	6.168	6.144	6.149	6.147	6.143	6.151	6.150	6.158	6.148	6.154
12	2858K	6.107	6.102	6.099	6.098	6.101	6.100	6.102	6.106	6.106	6.301
13	2808K	6.323	6.280	6.285	6.286	6.283	6.290	6.288	6.302	6.288	6.289
14	2864K	6.222	6.189	6.197	6.195	6.192	6.197	6.202	6.206	6.199	6.279
15	2809K	6.285	6.246	6.254	6.254	6.247	6.252	6.256	6.262	6.256	6.255
16	2841K	6.265	6.241	6.248	6.245	6.252	6.252	6.252	6.257	6.255	6.261
17	2866K	6.137	6.111	6.116	6.109	6.108	6.112	6.118	6.122	6.116	6.229
18	2821K	6.236	6.199	6.204	6.202	6.201	6.204	6.211	6.213	6.206	6.272
19	2773K	6.289	6.267	6.273	6.269	6.269	6.278	6.280	6.290	6.280	6.300
20	2774K	6.311	6.268	6.267	6.267	6.262	6.268	6.274	6.285	6.273	6.268
21	2762K	6.599	6.569	6.566	6.578	6.579	6.589	6.589	6.599	6.584	6.574
22	2764K	6.397	6.372	6.374	6.385	6.383	6.383	6.389	6.396	6.392	6.386
23	2731K	6.231	6.182	6.187	6.188	6.189	6.190	6.194	6.204	6.198	6.196
24	2722K	6.393	6.368	6.375	6.367	6.369	6.376	6.379	6.382	6.380	6.383
25	2741K	6.262	6.230	6.232	6.238	6.239	6.242	6.243	6.253	6.244	6.242

Luminous Flux [lm] data for tested units

$T_s = T_{air} = 85^{\circ}\text{C}$, $I_f = 165\text{mA}$; $T_s \geq 83^{\circ}\text{C}$ and $T_{air} \geq 80^{\circ}\text{C}$ in compliance with LM-80-08

	CCT (t=0)	0hrs	1000hrs	2000hrs	3000hrs	4000hrs	5000hrs	6000hrs	7000hrs	8000hrs	9000hrs
1	2850K	110.800	109.700	109.400	108.900	107.900	107.100	106.400	106.100	105.900	105.300
2	2866K	112.800	112.200	111.600	110.800	109.800	109.400	108.900	108.400	108.300	107.800
3	2797K	118.200	117.000	116.600	115.900	114.800	114.400	114.100	113.400	112.800	112.100
4	2824K	117.300	116.900	116.200	116.100	115.400	114.700	113.800	113.000	112.700	112.200
5	2863K	116.200	115.600	115.200	114.800	114.100	113.500	113.300	112.800	113.200	112.500
6	2870K	112.100	111.200	110.900	110.500	109.600	109.100	108.700	108.200	107.700	107.000
7	2870K	117.400	115.900	115.100	114.600	113.900	113.200	112.800	112.200	112.200	111.500
8	2868K	111.800	111.500	111.100	111.000	110.100	109.000	108.500	107.900	107.300	106.700
9	2860K	109.300	108.800	108.200	107.000	105.900	105.100	104.500	104.000	103.700	103.200
10	2799K	112.300	111.400	110.800	110.000	109.300	108.300	107.700	107.100	107.300	106.800
11	2850K	116.200	115.100	114.200	114.100	113.300	112.500	111.800	111.400	111.700	111.100
12	2865K	112.100	111.600	110.600	110.500	109.600	109.000	108.400	108.000	107.700	107.100
13	2849K	113.100	112.500	112.000	111.600	110.900	110.200	109.700	109.100	108.800	108.300
14	2869K	111.500	111.200	110.600	109.300	108.500	107.700	106.800	106.200	106.100	105.500
15	2845K	109.500	108.100	107.400	106.800	106.100	105.400	105.000	104.400	103.800	103.200
16	2809K	108.400	107.600	107.200	107.000	106.200	105.600	104.900	104.400	104.000	103.600
17	2868K	115.400	113.100	112.500	112.100	111.400	110.900	110.200	109.600	110.000	109.600
18	2819K	110.800	108.600	108.100	107.900	107.200	106.500	106.200	105.800	106.000	105.400
19	2870K	115.600	113.400	112.900	112.700	111.600	111.000	110.300	109.700	110.000	109.400
20	2825K	112.000	110.100	109.300	108.900	108.300	107.800	107.200	106.600	106.900	106.400
21	2838K	110.100	108.800	107.600	107.300	106.600	106.000	105.700	105.500	105.600	105.200
22	2867K	116.200	114.400	114.000	113.500	112.800	112.400	112.000	111.400	111.100	111.000
23	2756K	112.700	111.700	111.200	110.600	109.800	109.300	108.900	108.500	108.300	107.800
24	2730K	114.100	112.300	111.400	110.700	109.700	109.300	109.000	108.500	107.800	107.200
25	2839K	110.300	108.400	107.800	107.500	106.600	105.800	105.100	104.600	104.700	104.400

Normalized Luminous Flux data for tested units

$T_s = T_{air} = 85^{\circ}\text{C}$, $I_f = 165\text{mA}$; $T_s \geq 83^{\circ}\text{C}$ and $T_{air} \geq 80^{\circ}\text{C}$ in compliance with LM-80-08

	CCT (t=0)	0hrs	1000hrs	2000hrs	3000hrs	4000hrs	5000hrs	6000hrs	7000hrs	8000hrs	9000hrs
1	2850K	1.0000	0.9901	0.9874	0.9829	0.9738	0.9666	0.9603	0.9576	0.9558	0.9504
2	2866K	1.0000	0.9947	0.9894	0.9823	0.9734	0.9699	0.9654	0.9610	0.9601	0.9557
3	2797K	1.0000	0.9898	0.9865	0.9805	0.9712	0.9679	0.9653	0.9594	0.9543	0.9484
4	2824K	1.0000	0.9966	0.9906	0.9898	0.9838	0.9778	0.9702	0.9633	0.9608	0.9565
5	2863K	1.0000	0.9948	0.9914	0.9880	0.9819	0.9768	0.9750	0.9707	0.9742	0.9682
6	2870K	1.0000	0.9920	0.9893	0.9857	0.9777	0.9732	0.9697	0.9652	0.9607	0.9545
7	2870K	1.0000	0.9872	0.9804	0.9761	0.9702	0.9642	0.9608	0.9557	0.9557	0.9497
8	2868K	1.0000	0.9973	0.9937	0.9928	0.9848	0.9750	0.9705	0.9651	0.9597	0.9544
9	2860K	1.0000	0.9954	0.9899	0.9790	0.9689	0.9616	0.9561	0.9515	0.9488	0.9442
10	2799K	1.0000	0.9920	0.9866	0.9795	0.9733	0.9644	0.9590	0.9537	0.9555	0.9510
11	2850K	1.0000	0.9905	0.9828	0.9819	0.9750	0.9682	0.9621	0.9587	0.9613	0.9561
12	2865K	1.0000	0.9955	0.9866	0.9857	0.9777	0.9723	0.9670	0.9634	0.9607	0.9554
13	2849K	1.0000	0.9947	0.9903	0.9867	0.9805	0.9744	0.9699	0.9646	0.9620	0.9576
14	2869K	1.0000	0.9973	0.9919	0.9803	0.9731	0.9659	0.9578	0.9525	0.9516	0.9462
15	2845K	1.0000	0.9872	0.9808	0.9753	0.9689	0.9626	0.9589	0.9534	0.9479	0.9425
16	2809K	1.0000	0.9926	0.9889	0.9871	0.9797	0.9742	0.9677	0.9631	0.9594	0.9557
17	2868K	1.0000	0.9801	0.9749	0.9714	0.9653	0.9610	0.9549	0.9497	0.9532	0.9497
18	2819K	1.0000	0.9801	0.9756	0.9738	0.9675	0.9612	0.9585	0.9549	0.9567	0.9513
19	2870K	1.0000	0.9810	0.9766	0.9749	0.9654	0.9602	0.9542	0.9490	0.9516	0.9464
20	2825K	1.0000	0.9830	0.9759	0.9723	0.9670	0.9625	0.9571	0.9518	0.9545	0.9500
21	2838K	1.0000	0.9882	0.9773	0.9746	0.9682	0.9628	0.9600	0.9582	0.9591	0.9555
22	2867K	1.0000	0.9845	0.9811	0.9768	0.9707	0.9673	0.9639	0.9587	0.9561	0.9552
23	2756K	1.0000	0.9911	0.9867	0.9814	0.9743	0.9698	0.9663	0.9627	0.9610	0.9565
24	2730K	1.0000	0.9842	0.9763	0.9702	0.9614	0.9579	0.9553	0.9509	0.9448	0.9395
25	2839K	1.0000	0.9828	0.9773	0.9746	0.9665	0.9592	0.9529	0.9483	0.9492	0.9465

TM-21 Extrapolation of Luminous Flux data for tested units

$T_s = T_{air} = 85^{\circ}\text{C}$, $I_f = 165\text{mA}$; $T_s \geq 83^{\circ}\text{C}$ and $T_{air} \geq 80^{\circ}\text{C}$ in compliance with LM-80-08

	CCT (t=0)	alpha	B	L70
1	2850K	4.5310e-06	0.9894	76,373
2	2866K	3.6238e-06	0.9872	94,872
3	2797K	4.7831e-06	0.9914	72,764
4	2824K	5.7267e-06	1.0054	63,229
5	2863K	2.3707e-06	0.9896	146,040
6	2870K	4.6685e-06	0.9966	75,671
7	2870K	3.9553e-06	0.9844	86,192
8	2868K	5.9869e-06	1.0066	60,677
9	2860K	4.9760e-06	0.9865	68,955
10	2799K	4.2602e-06	0.9864	80,506
11	2850K	3.5153e-06	0.9858	97,400
12	2865K	4.4304e-06	0.9943	79,216
13	2849K	4.6417e-06	0.9978	76,365
14	2869K	5.4495e-06	0.9923	64,040
15	2845K	5.4339e-06	0.9900	63,794
16	2809K	4.9861e-06	0.9984	71,221
17	2868K	3.1816e-06	0.9756	104,347
18	2819K	2.9303e-06	0.9767	113,692
19	2870K	3.7759e-06	0.9781	88,606
20	2825K	3.4075e-06	0.9786	98,313
21	2838K	2.2668e-06	0.9749	146,131
22	2867K	3.4486e-06	0.9838	98,684
23	2756K	3.5191e-06	0.9874	97,754
24	2730K	4.6091e-06	0.9806	73,126
25	2839K	4.0112e-06	0.9789	83,611
ave	2838K	4.1795e-06	0.9879	82,416

CIE 1976 u' data for tested units

$T_s = T_{air} = 85^{\circ}\text{C}$, $I_f = 165\text{mA}$; $T_s \geq 83^{\circ}\text{C}$ and $T_{air} \geq 80^{\circ}\text{C}$ in compliance with LM-80-08

	CCT (t=0)	0hrs	1000hrs	2000hrs	3000hrs	4000hrs	5000hrs	6000hrs	7000hrs	8000hrs	9000hrs
1	2850K	0.2550	0.2536	0.2529	0.2529	0.2527	0.2524	0.2519	0.2514	0.2508	0.2505
2	2866K	0.2540	0.2530	0.2526	0.2525	0.2524	0.2521	0.2517	0.2515	0.2512	0.2510
3	2797K	0.2571	0.2557	0.2552	0.2548	0.2548	0.2545	0.2542	0.2540	0.2538	0.2536
4	2824K	0.2555	0.2541	0.2537	0.2533	0.2531	0.2530	0.2525	0.2523	0.2521	0.2518
5	2863K	0.2548	0.2528	0.2526	0.2526	0.2525	0.2523	0.2522	0.2518	0.2506	0.2494
6	2870K	0.2540	0.2522	0.2515	0.2514	0.2512	0.2511	0.2507	0.2503	0.2503	0.2502
7	2870K	0.2542	0.2535	0.2528	0.2525	0.2523	0.2522	0.2519	0.2514	0.2511	0.2510
8	2868K	0.2541	0.2532	0.2519	0.2521	0.2518	0.2515	0.2513	0.2512	0.2509	0.2506
9	2860K	0.2548	0.2538	0.2525	0.2525	0.2522	0.2520	0.2519	0.2514	0.2506	0.2502
10	2799K	0.2565	0.2552	0.2544	0.2542	0.2541	0.2538	0.2535	0.2535	0.2535	0.2531
11	2850K	0.2549	0.2537	0.2526	0.2524	0.2523	0.2520	0.2519	0.2513	0.2510	0.2509
12	2865K	0.2548	0.2538	0.2532	0.2528	0.2527	0.2524	0.2521	0.2514	0.2510	0.2507
13	2849K	0.2547	0.2535	0.2530	0.2528	0.2526	0.2525	0.2522	0.2518	0.2515	0.2511
14	2869K	0.2539	0.2532	0.2526	0.2524	0.2522	0.2519	0.2519	0.2512	0.2508	0.2506
15	2845K	0.2558	0.2544	0.2537	0.2535	0.2533	0.2530	0.2524	0.2522	0.2514	0.2507
16	2809K	0.2564	0.2552	0.2545	0.2542	0.2540	0.2537	0.2532	0.2529	0.2532	0.2525
17	2868K	0.2545	0.2536	0.2530	0.2532	0.2532	0.2531	0.2525	0.2521	0.2512	0.2503
18	2819K	0.2561	0.2552	0.2547	0.2543	0.2541	0.2539	0.2534	0.2533	0.2534	0.2527
19	2870K	0.2537	0.2527	0.2521	0.2519	0.2517	0.2514	0.2510	0.2505	0.2507	0.2505
20	2825K	0.2553	0.2544	0.2535	0.2530	0.2529	0.2529	0.2508	0.2506	0.2505	0.2505
21	2838K	0.2553	0.2540	0.2534	0.2533	0.2531	0.2528	0.2526	0.2523	0.2520	0.2518
22	2867K	0.2534	0.2528	0.2521	0.2518	0.2517	0.2513	0.2512	0.2509	0.2507	0.2504
23	2756K	0.2591	0.2578	0.2573	0.2572	0.2570	0.2567	0.2563	0.2560	0.2558	0.2555
24	2730K	0.2599	0.2588	0.2583	0.2582	0.2580	0.2578	0.2575	0.2570	0.2570	0.2567
25	2839K	0.2568	0.2554	0.2547	0.2547	0.2545	0.2542	0.2537	0.2534	0.2528	0.2528

CIE 1976 v' data for tested units

$T_s = T_{air} = 85^{\circ}\text{C}$, $I_f = 165\text{mA}$; $T_s \geq 83^{\circ}\text{C}$ and $T_{air} \geq 80^{\circ}\text{C}$ in compliance with LM-80-08

	CCT (t=0)	0hrs	1000hrs	2000hrs	3000hrs	4000hrs	5000hrs	6000hrs	7000hrs	8000hrs	9000hrs
1	2850K	0.5298	0.5286	0.5290	0.5287	0.5284	0.5282	0.5279	0.5277	0.5272	0.5267
2	2866K	0.5311	0.5307	0.5310	0.5305	0.5302	0.5300	0.5298	0.5296	0.5292	0.5288
3	2797K	0.5313	0.5306	0.5309	0.5305	0.5301	0.5299	0.5298	0.5297	0.5293	0.5288
4	2824K	0.5331	0.5326	0.5329	0.5323	0.5320	0.5318	0.5317	0.5315	0.5311	0.5307
5	2863K	0.5282	0.5270	0.5265	0.5264	0.5261	0.5259	0.5256	0.5258	0.5254	0.5245
6	2870K	0.5300	0.5298	0.5289	0.5285	0.5284	0.5281	0.5278	0.5272	0.5270	0.5270
7	2870K	0.5294	0.5302	0.5292	0.5287	0.5286	0.5283	0.5281	0.5276	0.5271	0.5269
8	2868K	0.5303	0.5309	0.5299	0.5295	0.5293	0.5291	0.5287	0.5284	0.5279	0.5276
9	2860K	0.5287	0.5292	0.5281	0.5275	0.5275	0.5273	0.5268	0.5265	0.5257	0.5255
10	2799K	0.5337	0.5344	0.5334	0.5328	0.5325	0.5323	0.5319	0.5315	0.5313	0.5311
11	2850K	0.5301	0.5305	0.5295	0.5290	0.5287	0.5286	0.5284	0.5277	0.5273	0.5272
12	2865K	0.5276	0.5281	0.5273	0.5267	0.5264	0.5262	0.5259	0.5252	0.5247	0.5245
13	2849K	0.5310	0.5316	0.5306	0.5301	0.5299	0.5297	0.5295	0.5292	0.5286	0.5283
14	2869K	0.5308	0.5316	0.5307	0.5301	0.5298	0.5296	0.5292	0.5288	0.5282	0.5280
15	2845K	0.5272	0.5277	0.5267	0.5260	0.5257	0.5254	0.5252	0.5248	0.5243	0.5237
16	2809K	0.5321	0.5328	0.5318	0.5312	0.5308	0.5306	0.5305	0.5301	0.5299	0.5294
17	2868K	0.5285	0.5290	0.5282	0.5276	0.5273	0.5271	0.5269	0.5269	0.5263	0.5257
18	2819K	0.5313	0.5319	0.5310	0.5304	0.5301	0.5299	0.5297	0.5290	0.5291	0.5288
19	2870K	0.5316	0.5324	0.5314	0.5308	0.5303	0.5300	0.5296	0.5291	0.5288	0.5286
20	2825K	0.5334	0.5342	0.5326	0.5323	0.5319	0.5317	0.5314	0.5311	0.5306	0.5303
21	2838K	0.5307	0.5312	0.5302	0.5297	0.5295	0.5294	0.5291	0.5287	0.5282	0.5278
22	2867K	0.5334	0.5341	0.5332	0.5326	0.5323	0.5323	0.5318	0.5315	0.5311	0.5307
23	2756K	0.5311	0.5311	0.5302	0.5297	0.5294	0.5293	0.5290	0.5287	0.5282	0.5278
24	2730K	0.5334	0.5337	0.5328	0.5323	0.5321	0.5319	0.5317	0.5313	0.5310	0.5306
25	2839K	0.5240	0.5239	0.5231	0.5227	0.5223	0.5222	0.5219	0.5215	0.5210	0.5205

Delta u'v' data for tested units

$T_s = T_{air} = 85^{\circ}\text{C}$, $I_f = 165\text{mA}$; $T_s \geq 83^{\circ}\text{C}$ and $T_{air} \geq 80^{\circ}\text{C}$ in compliance with LM-80-08

	CCT (t=0)	0hrs	1000hrs	2000hrs	3000hrs	4000hrs	5000hrs	6000hrs	7000hrs	8000hrs	9000hrs
1	2850K	0.0000	0.0018	0.0022	0.0024	0.0027	0.0031	0.0036	0.0042	0.0049	0.0055
2	2866K	0.0000	0.0011	0.0014	0.0016	0.0018	0.0022	0.0026	0.0029	0.0034	0.0038
3	2797K	0.0000	0.0016	0.0019	0.0024	0.0026	0.0030	0.0033	0.0035	0.0039	0.0043
4	2824K	0.0000	0.0015	0.0018	0.0023	0.0026	0.0028	0.0033	0.0036	0.0039	0.0044
5	2863K	0.0000	0.0023	0.0028	0.0028	0.0031	0.0034	0.0037	0.0038	0.0050	0.0065
6	2870K	0.0000	0.0018	0.0027	0.0030	0.0032	0.0035	0.0040	0.0046	0.0048	0.0048
7	2870K	0.0000	0.0011	0.0014	0.0018	0.0021	0.0023	0.0026	0.0033	0.0039	0.0041
8	2868K	0.0000	0.0011	0.0022	0.0022	0.0025	0.0029	0.0032	0.0035	0.0040	0.0044
9	2860K	0.0000	0.0011	0.0024	0.0026	0.0029	0.0031	0.0035	0.0040	0.0052	0.0056
10	2799K	0.0000	0.0015	0.0021	0.0025	0.0027	0.0030	0.0035	0.0037	0.0038	0.0043
11	2850K	0.0000	0.0013	0.0024	0.0027	0.0030	0.0033	0.0034	0.0043	0.0048	0.0049
12	2865K	0.0000	0.0011	0.0016	0.0022	0.0024	0.0028	0.0032	0.0042	0.0048	0.0051
13	2849K	0.0000	0.0013	0.0017	0.0021	0.0024	0.0026	0.0029	0.0034	0.0040	0.0045
14	2869K	0.0000	0.0011	0.0013	0.0017	0.0020	0.0023	0.0026	0.0034	0.0040	0.0043
15	2845K	0.0000	0.0015	0.0022	0.0026	0.0029	0.0033	0.0039	0.0043	0.0053	0.0062
16	2809K	0.0000	0.0014	0.0019	0.0024	0.0027	0.0031	0.0036	0.0040	0.0039	0.0047
17	2868K	0.0000	0.0010	0.0015	0.0016	0.0018	0.0020	0.0026	0.0029	0.0040	0.0050
18	2819K	0.0000	0.0011	0.0014	0.0020	0.0023	0.0026	0.0031	0.0036	0.0035	0.0042
19	2870K	0.0000	0.0013	0.0016	0.0020	0.0024	0.0028	0.0034	0.0041	0.0041	0.0044
20	2825K	0.0000	0.0012	0.0020	0.0025	0.0028	0.0029	0.0049	0.0052	0.0056	0.0057
21	2838K	0.0000	0.0014	0.0020	0.0022	0.0025	0.0028	0.0031	0.0036	0.0041	0.0045
22	2867K	0.0000	0.0009	0.0013	0.0018	0.0020	0.0024	0.0027	0.0031	0.0035	0.0040
23	2756K	0.0000	0.0013	0.0020	0.0024	0.0027	0.0030	0.0035	0.0039	0.0044	0.0049
24	2730K	0.0000	0.0011	0.0017	0.0020	0.0023	0.0026	0.0029	0.0036	0.0038	0.0043
25	2839K	0.0000	0.0014	0.0023	0.0025	0.0029	0.0032	0.0037	0.0042	0.0050	0.0053

Forward Voltage [V] data for tested units

$T_s = T_{air} = 85^{\circ}\text{C}$, $I_f = 165\text{mA}$; $T_s \geq 83^{\circ}\text{C}$ and $T_{air} \geq 80^{\circ}\text{C}$ in compliance with LM-80-08

	CCT (t=0)	0hrs	1000hrs	2000hrs	3000hrs	4000hrs	5000hrs	6000hrs	7000hrs	8000hrs	9000hrs
1	2850K	6.243	6.209	6.208	6.213	6.227	6.223	6.220	6.223	6.223	6.299
2	2866K	6.113	6.107	6.108	6.113	6.124	6.114	6.118	6.123	6.122	6.120
3	2797K	6.043	6.033	6.035	6.040	6.050	6.046	6.044	6.049	6.052	6.043
4	2824K	6.243	6.216	6.219	6.224	6.243	6.237	6.238	6.243	6.238	6.228
5	2863K	6.318	6.284	6.289	6.301	6.320	6.310	6.313	6.321	6.310	6.306
6	2870K	6.224	6.197	6.203	6.205	6.221	6.212	6.212	6.222	6.216	6.211
7	2870K	6.060	6.047	6.048	6.047	6.056	6.049	6.059	6.064	6.054	6.051
8	2868K	6.249	6.225	6.223	6.229	6.239	6.234	6.235	6.247	6.232	6.233
9	2860K	6.238	6.221	6.223	6.224	6.228	6.228	6.228	6.235	6.229	6.229
10	2799K	6.181	6.159	6.157	6.159	6.169	6.165	6.163	6.172	6.163	6.154
11	2850K	6.028	6.019	6.019	6.016	6.026	6.022	6.026	6.028	6.023	6.020
12	2865K	6.245	6.223	6.225	6.226	6.237	6.234	6.232	6.242	6.235	6.229
13	2849K	6.118	6.114	6.116	6.117	6.122	6.121	6.123	6.129	6.122	6.119
14	2869K	6.094	6.091	6.098	6.098	6.103	6.099	6.103	6.108	6.102	6.109
15	2845K	6.239	6.216	6.222	6.226	6.235	6.235	6.235	6.243	6.235	6.256
16	2809K	6.185	6.157	6.161	6.163	6.163	6.166	6.162	6.174	6.166	6.270
17	2868K	6.214	6.193	6.192	6.197	6.206	6.201	6.205	6.210	6.203	6.251
18	2819K	6.204	6.179	6.177	6.179	6.191	6.189	6.188	6.195	6.185	6.185
19	2870K	6.132	6.113	6.108	6.109	6.120	6.114	6.117	6.130	6.118	6.259
20	2825K	6.267	6.235	6.237	6.236	6.248	6.242	6.238	6.253	6.243	6.254
21	2838K	6.220	6.205	6.200	6.206	6.214	6.211	6.212	6.221	6.212	6.218
22	2867K	6.222	6.193	6.193	6.197	6.206	6.201	6.204	6.217	6.203	6.202
23	2756K	6.339	6.297	6.296	6.299	6.309	6.305	6.310	6.318	6.308	6.299
24	2730K	6.530	6.488	6.484	6.495	6.513	6.512	6.514	6.521	6.569	6.502
25	2839K	6.203	6.177	6.175	6.183	6.192	6.185	6.187	6.191	6.190	6.183

Luminous Flux [lm] data for tested units

$T_s = T_{air} = 105^{\circ}\text{C}$, $I_f = 165\text{mA}$; $T_s \geq 103^{\circ}\text{C}$ and $T_{air} \geq 100^{\circ}\text{C}$ in compliance with LM-80-08

	CCT (t=0)	0hrs	1000hrs	2000hrs	3000hrs	4000hrs	5000hrs	6000hrs	7000hrs	8000hrs	9000hrs
1	2860K	112.400	112.100	111.400	110.300	109.400	108.900	108.200	107.800	107.600	106.900
2	2838K	113.100	112.300	111.500	111.000	109.900	109.200	108.600	108.400	107.700	107.100
3	2793K	109.700	108.400	107.900	106.900	105.900	105.500	105.100	104.500	104.100	103.500
4	2806K	116.300	114.700	113.400	113.200	112.300	111.600	111.000	110.500	110.100	109.200
5	2863K	112.800	111.300	110.100	109.600	108.600	107.900	107.100	106.700	107.000	106.200
6	2861K	112.200	111.500	110.900	110.300	109.300	108.500	107.800	107.200	106.400	105.600
7	2846K	112.100	110.800	110.200	109.600	108.700	108.200	107.600	107.100	107.300	106.700
8	2815K	111.900	110.600	109.800	108.600	107.600	107.100	106.800	106.300	105.800	104.800
9	2828K	115.000	114.300	113.200	112.900	111.500	110.900	109.900	109.500	109.300	108.500
10	2798K	111.800	111.200	110.400	108.800	107.700	106.900	106.500	106.000	105.500	104.600
11	2847K	109.600	109.100	108.400	107.900	107.000	106.500	105.700	105.200	105.400	104.800
12	2858K	114.400	113.500	112.700	112.200	111.100	110.100	109.300	108.800	108.800	108.000
13	2854K	112.300	110.700	109.900	109.500	108.200	107.600	107.100	106.500	106.400	105.700
14	2841K	114.200	112.100	111.300	111.000	110.200	110.000	109.600	109.200	109.300	108.600
15	2846K	113.200	111.500	110.600	110.100	109.100	109.000	108.500	108.000	107.500	106.800
16	2821K	118.600	117.100	116.100	116.000	115.100	114.600	114.000	113.800	114.100	113.200
17	2810K	117.500	116.600	115.700	115.300	113.900	113.500	112.900	112.300	112.400	111.500
18	2705K	112.400	111.200	110.400	110.100	108.900	108.400	107.900	107.300	107.700	107.000
19	2790K	107.200	105.800	104.600	104.000	102.800	102.600	102.200	101.600	101.500	100.900
20	2765K	113.700	111.500	110.800	110.500	109.300	108.700	108.200	109.000	109.200	108.600
21	2776K	110.500	108.600	107.800	107.700	106.500	106.000	105.100	104.900	104.300	103.100
22	2737K	114.700	112.800	112.200	112.100	110.800	110.400	109.800	109.200	109.500	108.600
23	2767K	104.300	103.300	102.500	102.200	101.200	100.800	100.000	99.560	99.220	98.300
24	2762K	102.500	102.000	101.200	100.900	100.200	99.760	99.440	99.060	99.150	98.360
25	2798K	112.000	110.700	109.400	108.700	107.600	107.100	106.300	105.800	106.000	105.300

Normalized Luminous Flux data for tested units

$T_s = T_{air} = 105^{\circ}\text{C}$, $I_f = 165\text{mA}$; $T_s \geq 103^{\circ}\text{C}$ and $T_{air} \geq 100^{\circ}\text{C}$ in compliance with LM-80-08

	CCT (t=0)	0hrs	1000hrs	2000hrs	3000hrs	4000hrs	5000hrs	6000hrs	7000hrs	8000hrs	9000hrs
1	2860K	1.0000	0.9973	0.9911	0.9813	0.9733	0.9689	0.9626	0.9591	0.9573	0.9511
2	2838K	1.0000	0.9929	0.9859	0.9814	0.9717	0.9655	0.9602	0.9584	0.9523	0.9469
3	2793K	1.0000	0.9881	0.9836	0.9745	0.9654	0.9617	0.9581	0.9526	0.9490	0.9435
4	2806K	1.0000	0.9862	0.9751	0.9733	0.9656	0.9596	0.9544	0.9501	0.9467	0.9390
5	2863K	1.0000	0.9867	0.9761	0.9716	0.9628	0.9566	0.9495	0.9459	0.9486	0.9415
6	2861K	1.0000	0.9938	0.9884	0.9831	0.9742	0.9670	0.9608	0.9554	0.9483	0.9412
7	2846K	1.0000	0.9884	0.9831	0.9777	0.9697	0.9652	0.9599	0.9554	0.9572	0.9518
8	2815K	1.0000	0.9884	0.9812	0.9705	0.9616	0.9571	0.9544	0.9500	0.9455	0.9366
9	2828K	1.0000	0.9939	0.9843	0.9817	0.9696	0.9643	0.9557	0.9522	0.9504	0.9435
10	2798K	1.0000	0.9946	0.9875	0.9732	0.9633	0.9562	0.9526	0.9481	0.9436	0.9356
11	2847K	1.0000	0.9954	0.9891	0.9845	0.9763	0.9717	0.9644	0.9599	0.9617	0.9562
12	2858K	1.0000	0.9921	0.9851	0.9808	0.9712	0.9624	0.9554	0.9510	0.9510	0.9441
13	2854K	1.0000	0.9858	0.9786	0.9751	0.9635	0.9581	0.9537	0.9484	0.9475	0.9412
14	2841K	1.0000	0.9816	0.9746	0.9720	0.9650	0.9632	0.9597	0.9562	0.9571	0.9510
15	2846K	1.0000	0.9850	0.9770	0.9726	0.9638	0.9629	0.9585	0.9541	0.9496	0.9435
16	2821K	1.0000	0.9874	0.9789	0.9781	0.9705	0.9663	0.9612	0.9595	0.9621	0.9545
17	2810K	1.0000	0.9923	0.9847	0.9813	0.9694	0.9660	0.9609	0.9557	0.9566	0.9489
18	2705K	1.0000	0.9893	0.9822	0.9795	0.9689	0.9644	0.9600	0.9546	0.9582	0.9520
19	2790K	1.0000	0.9869	0.9757	0.9701	0.9590	0.9571	0.9534	0.9478	0.9468	0.9412
20	2765K	1.0000	0.9807	0.9745	0.9719	0.9613	0.9560	0.9516	0.9587	0.9604	0.9551
21	2776K	1.0000	0.9828	0.9756	0.9747	0.9638	0.9593	0.9511	0.9493	0.9439	0.9330
22	2737K	1.0000	0.9834	0.9782	0.9773	0.9660	0.9625	0.9573	0.9520	0.9547	0.9468
23	2767K	1.0000	0.9904	0.9827	0.9799	0.9703	0.9664	0.9588	0.9546	0.9513	0.9425
24	2762K	1.0000	0.9951	0.9873	0.9844	0.9776	0.9733	0.9701	0.9664	0.9673	0.9596
25	2798K	1.0000	0.9884	0.9768	0.9705	0.9607	0.9562	0.9491	0.9446	0.9464	0.9402

TM-21 Extrapolation of Luminous Flux data for tested units

$T_s = T_{air} = 105^{\circ}C$, $I_f = 165mA$; $T_s \geq 103^{\circ}C$ and $T_{air} \geq 100^{\circ}C$ in compliance with LM-80-08

	CCT (t=0)	alpha	B	L70
1	2860K	4.4376e-06	0.9902	78,148
2	2838K	4.9251e-06	0.9903	70,451
3	2793K	4.5834e-06	0.9839	74,272
4	2806K	5.2878e-06	0.9858	64,754
5	2863K	4.0173e-06	0.9759	82,718
6	2861K	6.7544e-06	1.0007	52,915
7	2846K	3.5020e-06	0.9819	96,645
8	2815K	4.9476e-06	0.9819	68,397
9	2828K	5.2462e-06	0.9891	65,891
10	2798K	5.4367e-06	0.9840	62,645
11	2847K	3.9933e-06	0.9904	86,897
12	2858K	5.1919e-06	0.9886	66,495
13	2854K	4.4613e-06	0.9800	75,431
14	2841K	2.7410e-06	0.9759	121,233
15	2846K	4.3636e-06	0.9828	77,774
16	2821K	2.8028e-06	0.9800	120,054
17	2810K	4.0293e-06	0.9850	84,772
18	2705K	3.2291e-06	0.9800	104,203
19	2790K	3.7572e-06	0.9744	88,017
20	2765K	3.1402e-07	0.9591	1,003,015
21	2776K	6.0753e-06	0.9883	56,770
22	2737K	3.7232e-06	0.9800	90,361
23	2767K	5.6337e-06	0.9930	62,057
24	2762K	3.2828e-06	0.9899	105,569
25	2798K	4.1064e-06	0.9752	80,747
ave	2811K	4.2712e-06	0.9834	79,596

CIE 1976 u' data for tested units

$T_s = T_{air} = 105^{\circ}C$, $I_f = 165mA$; $T_s \geq 103^{\circ}C$ and $T_{air} \geq 100^{\circ}C$ in compliance with LM-80-08

	CCT (t=0)	0hrs	1000hrs	2000hrs	3000hrs	4000hrs	5000hrs	6000hrs	7000hrs	8000hrs	9000hrs
1	2860K	0.2541	0.2527	0.2522	0.2519	0.2517	0.2516	0.2515	0.2513	0.2510	0.2505
2	2838K	0.2553	0.2539	0.2535	0.2543	0.2540	0.2539	0.2537	0.2536	0.2536	0.2526
3	2793K	0.2573	0.2557	0.2546	0.2543	0.2541	0.2539	0.2536	0.2532	0.2524	0.2521
4	2806K	0.2565	0.2551	0.2543	0.2542	0.2539	0.2538	0.2532	0.2528	0.2526	0.2522
5	2863K	0.2547	0.2535	0.2529	0.2523	0.2522	0.2520	0.2516	0.2512	0.2510	0.2505
6	2861K	0.2547	0.2536	0.2530	0.2526	0.2524	0.2523	0.2518	0.2515	0.2515	0.2510
7	2846K	0.2550	0.2540	0.2532	0.2530	0.2529	0.2526	0.2522	0.2517	0.2514	0.2510
8	2815K	0.2561	0.2548	0.2547	0.2541	0.2538	0.2535	0.2532	0.2529	0.2525	0.2520
9	2828K	0.2559	0.2544	0.2542	0.2536	0.2535	0.2534	0.2528	0.2524	0.2519	0.2517
10	2798K	0.2568	0.2554	0.2552	0.2549	0.2546	0.2544	0.2537	0.2535	0.2531	0.2526
11	2847K	0.2554	0.2534	0.2533	0.2526	0.2525	0.2524	0.2519	0.2517	0.2513	0.2510
12	2858K	0.2546	0.2529	0.2524	0.2522	0.2520	0.2518	0.2510	0.2507	0.2504	0.2499
13	2854K	0.2549	0.2533	0.2529	0.2526	0.2524	0.2522	0.2515	0.2511	0.2509	0.2504
14	2841K	0.2550	0.2534	0.2530	0.2529	0.2528	0.2527	0.2521	0.2517	0.2516	0.2514
15	2846K	0.2555	0.2536	0.2531	0.2529	0.2527	0.2525	0.2520	0.2516	0.2512	0.2509
16	2821K	0.2560	0.2549	0.2547	0.2542	0.2540	0.2535	0.2529	0.2524	0.2523	0.2521
17	2810K	0.2562	0.2548	0.2546	0.2538	0.2537	0.2535	0.2529	0.2525	0.2524	0.2521
18	2705K	0.2612	0.2601	0.2597	0.2596	0.2593	0.2592	0.2585	0.2582	0.2581	0.2577
19	2790K	0.2585	0.2569	0.2564	0.2559	0.2557	0.2554	0.2547	0.2544	0.2543	0.2540
20	2765K	0.2588	0.2577	0.2573	0.2569	0.2568	0.2563	0.2557	0.2553	0.2551	0.2548
21	2776K	0.2588	0.2577	0.2572	0.2569	0.2567	0.2565	0.2561	0.2557	0.2556	0.2553
22	2737K	0.2596	0.2585	0.2579	0.2577	0.2575	0.2571	0.2567	0.2563	0.2561	0.2556
23	2767K	0.2591	0.2576	0.2572	0.2571	0.2569	0.2566	0.2561	0.2559	0.2556	0.2551
24	2762K	0.2596	0.2582	0.2577	0.2573	0.2571	0.2570	0.2558	0.2555	0.2554	0.2551
25	2798K	0.2577	0.2562	0.2557	0.2556	0.2555	0.2552	0.2546	0.2542	0.2541	0.2538

CIE 1976 v' data for tested units

$T_s = T_{air} = 105^{\circ}\text{C}$, $I_f = 165\text{mA}$; $T_s \geq 103^{\circ}\text{C}$ and $T_{air} \geq 100^{\circ}\text{C}$ in compliance with LM-80-08

	CCT (t=0)	0hrs	1000hrs	2000hrs	3000hrs	4000hrs	5000hrs	6000hrs	7000hrs	8000hrs	9000hrs
1	2860K	0.5320	0.5320	0.5316	0.5315	0.5311	0.5309	0.5304	0.5302	0.5302	0.5298
2	2838K	0.5309	0.5309	0.5304	0.5293	0.5292	0.5289	0.5284	0.5283	0.5287	0.5287
3	2793K	0.5311	0.5311	0.5305	0.5305	0.5302	0.5299	0.5294	0.5290	0.5284	0.5283
4	2806K	0.5319	0.5320	0.5314	0.5315	0.5311	0.5309	0.5304	0.5300	0.5296	0.5295
5	2863K	0.5287	0.5286	0.5280	0.5281	0.5277	0.5274	0.5270	0.5267	0.5261	0.5260
6	2861K	0.5290	0.5290	0.5286	0.5286	0.5283	0.5280	0.5275	0.5272	0.5267	0.5266
7	2846K	0.5308	0.5309	0.5305	0.5305	0.5302	0.5298	0.5293	0.5290	0.5286	0.5284
8	2815K	0.5319	0.5321	0.5316	0.5312	0.5311	0.5307	0.5304	0.5301	0.5296	0.5294
9	2828K	0.5303	0.5302	0.5299	0.5297	0.5293	0.5292	0.5286	0.5284	0.5280	0.5277
10	2798K	0.5326	0.5327	0.5323	0.5321	0.5316	0.5314	0.5310	0.5308	0.5304	0.5301
11	2847K	0.5288	0.5285	0.5281	0.5280	0.5276	0.5273	0.5268	0.5266	0.5262	0.5259
12	2858K	0.5299	0.5298	0.5294	0.5293	0.5289	0.5287	0.5281	0.5278	0.5274	0.5271
13	2854K	0.5293	0.5293	0.5288	0.5288	0.5284	0.5282	0.5276	0.5273	0.5270	0.5266
14	2841K	0.5314	0.5316	0.5310	0.5311	0.5308	0.5306	0.5300	0.5298	0.5295	0.5293
15	2846K	0.5285	0.5281	0.5277	0.5278	0.5274	0.5271	0.5266	0.5263	0.5259	0.5257
16	2821K	0.5309	0.5311	0.5307	0.5307	0.5304	0.5301	0.5293	0.5290	0.5288	0.5286
17	2810K	0.5327	0.5328	0.5324	0.5322	0.5318	0.5315	0.5311	0.5308	0.5306	0.5303
18	2705K	0.5330	0.5330	0.5325	0.5325	0.5321	0.5318	0.5314	0.5311	0.5308	0.5305
19	2790K	0.5261	0.5258	0.5253	0.5250	0.5246	0.5244	0.5239	0.5236	0.5233	0.5229
20	2765K	0.5303	0.5304	0.5297	0.5297	0.5292	0.5290	0.5285	0.5282	0.5279	0.5276
21	2776K	0.5277	0.5275	0.5271	0.5271	0.5266	0.5263	0.5260	0.5256	0.5254	0.5251
22	2737K	0.5327	0.5326	0.5321	0.5322	0.5317	0.5313	0.5310	0.5307	0.5305	0.5301
23	2767K	0.5286	0.5283	0.5278	0.5280	0.5275	0.5271	0.5267	0.5265	0.5261	0.5257
24	2762K	0.5270	0.5264	0.5260	0.5260	0.5257	0.5254	0.5247	0.5245	0.5242	0.5239
25	2798K	0.5284	0.5282	0.5278	0.5278	0.5274	0.5272	0.5266	0.5263	0.5260	0.5258

Delta u'v' data for tested units

$T_s = T_{air} = 105^{\circ}\text{C}$, $I_f = 165\text{mA}$; $T_s \geq 103^{\circ}\text{C}$ and $T_{air} \geq 100^{\circ}\text{C}$ in compliance with LM-80-08

	CCT (t=0)	0hrs	1000hrs	2000hrs	3000hrs	4000hrs	5000hrs	6000hrs	7000hrs	8000hrs	9000hrs
1	2860K	0.0000	0.0014	0.0019	0.0023	0.0026	0.0027	0.0031	0.0033	0.0036	0.0042
2	2838K	0.0000	0.0014	0.0019	0.0019	0.0021	0.0024	0.0030	0.0031	0.0028	0.0035
3	2793K	0.0000	0.0016	0.0028	0.0031	0.0033	0.0036	0.0041	0.0046	0.0056	0.0059
4	2806K	0.0000	0.0014	0.0023	0.0023	0.0027	0.0029	0.0036	0.0042	0.0045	0.0049
5	2863K	0.0000	0.0012	0.0019	0.0025	0.0027	0.0030	0.0035	0.0040	0.0045	0.0050
6	2861K	0.0000	0.0011	0.0017	0.0021	0.0024	0.0026	0.0033	0.0037	0.0039	0.0044
7	2846K	0.0000	0.0010	0.0018	0.0020	0.0022	0.0026	0.0032	0.0038	0.0042	0.0047
8	2815K	0.0000	0.0013	0.0014	0.0021	0.0024	0.0029	0.0033	0.0037	0.0043	0.0048
9	2828K	0.0000	0.0015	0.0017	0.0024	0.0026	0.0027	0.0035	0.0040	0.0046	0.0049
10	2798K	0.0000	0.0014	0.0016	0.0020	0.0024	0.0027	0.0035	0.0038	0.0043	0.0049
11	2847K	0.0000	0.0020	0.0022	0.0029	0.0031	0.0034	0.0040	0.0043	0.0049	0.0053
12	2858K	0.0000	0.0017	0.0023	0.0025	0.0028	0.0030	0.0040	0.0044	0.0049	0.0055
13	2854K	0.0000	0.0016	0.0021	0.0024	0.0027	0.0029	0.0038	0.0043	0.0046	0.0052
14	2841K	0.0000	0.0016	0.0020	0.0021	0.0023	0.0024	0.0032	0.0037	0.0039	0.0042
15	2846K	0.0000	0.0019	0.0025	0.0027	0.0030	0.0033	0.0040	0.0045	0.0050	0.0054
16	2821K	0.0000	0.0011	0.0013	0.0018	0.0021	0.0026	0.0035	0.0041	0.0043	0.0045
17	2810K	0.0000	0.0014	0.0016	0.0025	0.0027	0.0030	0.0037	0.0042	0.0043	0.0048
18	2705K	0.0000	0.0011	0.0016	0.0017	0.0021	0.0023	0.0031	0.0036	0.0038	0.0043
19	2790K	0.0000	0.0016	0.0022	0.0028	0.0032	0.0035	0.0044	0.0048	0.0050	0.0055
20	2765K	0.0000	0.0011	0.0016	0.0020	0.0023	0.0028	0.0036	0.0041	0.0044	0.0048
21	2776K	0.0000	0.0011	0.0017	0.0020	0.0024	0.0027	0.0032	0.0037	0.0039	0.0044
22	2737K	0.0000	0.0011	0.0018	0.0020	0.0023	0.0029	0.0034	0.0039	0.0041	0.0048
23	2767K	0.0000	0.0015	0.0021	0.0021	0.0025	0.0029	0.0036	0.0038	0.0043	0.0049
24	2762K	0.0000	0.0015	0.0021	0.0025	0.0028	0.0031	0.0044	0.0048	0.0050	0.0055
25	2798K	0.0000	0.0015	0.0021	0.0022	0.0024	0.0028	0.0036	0.0041	0.0043	0.0047

Forward Voltage [V] data for tested units

$T_s = T_{air} = 105^{\circ}\text{C}$, $I_f = 165\text{mA}$; $T_s \geq 103^{\circ}\text{C}$ and $T_{air} \geq 100^{\circ}\text{C}$ in compliance with LM-80-08

	CCT (t=0)	0hrs	1000hrs	2000hrs	3000hrs	4000hrs	5000hrs	6000hrs	7000hrs	8000hrs	9000hrs
1	2860K	6.194	6.173	6.173	6.182	6.186	6.192	6.206	6.203	6.194	6.192
2	2838K	6.209	6.174	6.177	6.200	6.181	6.208	6.196	6.287	6.273	6.269
3	2793K	6.277	6.248	6.246	6.255	6.263	6.275	6.280	6.286	6.268	6.266
4	2806K	6.070	6.055	6.059	6.062	6.071	6.068	6.078	6.083	6.081	6.107
5	2863K	6.215	6.190	6.192	6.200	6.207	6.210	6.217	6.219	6.218	6.210
6	2861K	6.329	6.297	6.304	6.320	6.331	6.333	6.344	6.349	6.346	6.338
7	2846K	6.247	6.218	6.222	6.233	6.244	6.244	6.252	6.250	6.250	6.245
8	2815K	6.238	6.217	6.218	6.217	6.227	6.228	6.234	6.238	6.235	6.237
9	2828K	6.231	6.205	6.210	6.213	6.219	6.223	6.225	6.233	6.229	6.242
10	2798K	6.229	6.198	6.203	6.205	6.211	6.213	6.206	6.213	6.213	6.203
11	2847K	6.221	6.189	6.192	6.202	6.216	6.219	6.220	6.225	6.227	6.213
12	2858K	6.266	6.236	6.243	6.248	6.261	6.264	6.265	6.271	6.276	6.259
13	2854K	6.175	6.153	6.155	6.163	6.169	6.173	6.176	6.182	6.188	6.170
14	2841K	6.035	6.031	6.030	6.039	6.042	6.044	6.052	6.053	6.058	6.045
15	2846K	6.339	6.383	6.385	6.442	6.454	6.454	6.462	6.461	6.465	6.450
16	2821K	6.013	6.005	6.006	6.007	6.005	6.010	6.015	6.019	6.019	6.009
17	2810K	6.297	6.269	6.268	6.282	6.284	6.295	6.297	6.302	6.293	6.288
18	2705K	6.447	6.402	6.402	6.413	6.424	6.423	6.436	6.439	6.429	6.421
19	2790K	6.424	6.390	6.391	6.379	6.395	6.402	6.415	6.413	6.410	6.401
20	2765K	6.275	6.245	6.244	6.242	6.241	6.242	6.254	6.252	6.249	6.247
21	2776K	6.250	6.225	6.223	6.239	6.239	6.240	6.249	6.255	6.249	6.242
22	2737K	6.253	6.222	6.220	6.230	6.232	6.235	6.239	6.247	6.251	6.236
23	2767K	6.322	6.280	6.276	6.286	6.291	6.298	6.302	6.306	6.314	6.287
24	2762K	6.518	6.480	6.478	6.484	6.490	6.488	6.497	6.504	6.499	6.482
25	2798K	6.328	6.310	6.310	6.326	6.329	6.329	6.340	6.341	6.335	6.330

Luminous Flux [lm] data for tested units

$T_s = T_{air} = 55^{\circ}C, I_f = 200mA; T_s \geq 53^{\circ}C$ and $T_{air} \geq 50^{\circ}C$ in compliance with LM-80-08

	CCT (t=0)	0hrs	1000hrs	2000hrs	3000hrs	4000hrs	5000hrs	6000hrs	7000hrs	8000hrs	9000hrs
1	2846K	133.400	132.600	132.000	131.800	131.200	129.600	129.300	128.900	128.100	127.500
2	2842K	136.000	135.100	134.400	134.100	133.600	133.200	132.400	132.000	131.300	130.800
3	2863K	138.100	136.600	135.900	135.500	134.900	134.400	133.600	133.000	132.200	131.600
4	2856K	133.900	132.200	131.300	131.200	130.400	130.100	129.500	129.100	128.400	127.700
5	2839K	131.900	131.800	131.000	130.900	130.400	129.700	129.300	128.800	128.200	127.500
6	2863K	136.500	135.700	134.900	134.300	133.800	133.300	132.700	132.100	131.700	130.800
7	2828K	134.900	134.000	133.100	132.500	131.900	131.200	130.800	130.200	129.500	128.800
8	2827K	136.800	135.800	134.900	134.000	133.400	132.800	132.200	131.900	130.400	129.800
9	2807K	138.500	137.400	136.600	135.800	134.800	134.100	133.700	133.300	132.700	132.100
10	2829K	136.100	135.200	134.700	134.100	133.000	132.600	132.200	131.800	131.100	130.400
11	2838K	136.600	135.500	134.400	133.700	133.000	132.500	131.800	131.300	130.600	130.000
12	2852K	137.100	136.000	134.800	134.600	133.600	133.100	132.800	132.400	131.600	130.800
13	2854K	133.300	132.400	131.500	130.800	130.000	129.800	129.200	128.800	127.900	127.100
14	2856K	137.700	136.700	136.100	135.800	135.300	134.900	134.600	133.900	133.400	132.700
15	2848K	136.600	135.900	134.700	134.300	133.500	133.200	132.600	132.100	131.600	130.900
16	2863K	137.800	137.400	136.800	136.400	135.700	135.100	134.400	133.900	133.300	132.600
17	2844K	136.800	135.700	134.900	134.500	134.000	133.400	132.900	132.300	131.700	131.000
18	2767K	135.000	134.500	133.600	133.200	132.500	132.000	131.800	131.300	130.700	130.100
19	2808K	135.300	134.200	133.700	132.800	132.200	131.500	130.600	129.900	129.300	128.600
20	2742K	128.500	127.900	127.000	125.400	124.700	124.100	123.400	123.200	122.400	121.800
21	2761K	122.300	122.000	120.900	120.200	119.500	119.000	118.600	118.300	117.800	117.200
22	2766K	127.500	127.400	126.300	124.700	123.800	123.400	123.000	122.600	121.800	121.000
23	2732K	129.400	128.500	127.500	126.700	126.100	125.600	124.700	124.300	123.600	123.000
24	2746K	127.700	126.500	125.800	125.200	124.500	124.100	123.500	120.400	119.700	119.100
25	2765K	130.600	129.600	128.700	128.200	127.200	126.800	126.000	125.400	124.700	124.000

Normalized Luminous Flux data for tested units

$T_s = T_{air} = 55^{\circ}C, I_f = 200mA; T_s \geq 53^{\circ}C$ and $T_{air} \geq 50^{\circ}C$ in compliance with LM-80-08

	CCT (t=0)	0hrs	1000hrs	2000hrs	3000hrs	4000hrs	5000hrs	6000hrs	7000hrs	8000hrs	9000hrs
1	2846K	1.0000	0.9940	0.9895	0.9880	0.9835	0.9715	0.9693	0.9663	0.9603	0.9558
2	2842K	1.0000	0.9934	0.9882	0.9860	0.9824	0.9794	0.9735	0.9706	0.9654	0.9618
3	2863K	1.0000	0.9891	0.9841	0.9812	0.9768	0.9732	0.9674	0.9631	0.9573	0.9529
4	2856K	1.0000	0.9873	0.9806	0.9798	0.9739	0.9716	0.9671	0.9642	0.9589	0.9537
5	2839K	1.0000	0.9992	0.9932	0.9924	0.9886	0.9833	0.9803	0.9765	0.9719	0.9666
6	2863K	1.0000	0.9941	0.9883	0.9839	0.9802	0.9766	0.9722	0.9678	0.9648	0.9582
7	2828K	1.0000	0.9933	0.9867	0.9822	0.9778	0.9726	0.9696	0.9652	0.9600	0.9548
8	2827K	1.0000	0.9927	0.9861	0.9795	0.9751	0.9708	0.9664	0.9642	0.9532	0.9488
9	2807K	1.0000	0.9921	0.9863	0.9805	0.9733	0.9682	0.9653	0.9625	0.9581	0.9538
10	2829K	1.0000	0.9934	0.9897	0.9853	0.9772	0.9743	0.9713	0.9684	0.9633	0.9581
11	2838K	1.0000	0.9919	0.9839	0.9788	0.9736	0.9700	0.9649	0.9612	0.9561	0.9517
12	2852K	1.0000	0.9920	0.9832	0.9818	0.9745	0.9708	0.9686	0.9657	0.9599	0.9540
13	2854K	1.0000	0.9932	0.9865	0.9812	0.9752	0.9737	0.9692	0.9662	0.9595	0.9535
14	2856K	1.0000	0.9927	0.9884	0.9862	0.9826	0.9797	0.9775	0.9724	0.9688	0.9637
15	2848K	1.0000	0.9949	0.9861	0.9832	0.9773	0.9751	0.9707	0.9671	0.9634	0.9583
16	2863K	1.0000	0.9971	0.9927	0.9898	0.9848	0.9804	0.9753	0.9717	0.9673	0.9623
17	2844K	1.0000	0.9920	0.9861	0.9832	0.9795	0.9751	0.9715	0.9671	0.9627	0.9576
18	2767K	1.0000	0.9963	0.9896	0.9867	0.9815	0.9778	0.9763	0.9726	0.9681	0.9637
19	2808K	1.0000	0.9919	0.9882	0.9815	0.9771	0.9719	0.9653	0.9601	0.9557	0.9505
20	2742K	1.0000	0.9953	0.9883	0.9759	0.9704	0.9658	0.9603	0.9588	0.9525	0.9479
21	2761K	1.0000	0.9975	0.9886	0.9828	0.9771	0.9730	0.9697	0.9673	0.9632	0.9583
22	2766K	1.0000	0.9992	0.9906	0.9780	0.9710	0.9678	0.9647	0.9616	0.9553	0.9490
23	2732K	1.0000	0.9930	0.9853	0.9791	0.9745	0.9706	0.9637	0.9606	0.9552	0.9505
24	2746K	1.0000	0.9906	0.9851	0.9804	0.9749	0.9718	0.9671	0.9428	0.9374	0.9327
25	2765K	1.0000	0.9923	0.9855	0.9816	0.9740	0.9709	0.9648	0.9602	0.9548	0.9495

TM-21 Extrapolation of Luminous Flux data for tested units

$T_s = T_{air} = 55^{\circ}\text{C}$, $I_f = 200\text{mA}$; $T_s \geq 53^{\circ}\text{C}$ and $T_{air} \geq 50^{\circ}\text{C}$ in compliance with LM-80-08

	CCT (t=0)	alpha	B	L70
1	2846K	5.1730e-06	1.0008	69,107
2	2842K	4.3437e-06	1.0000	82,111
3	2863K	5.0814e-06	0.9975	69,699
4	2856K	4.2048e-06	0.9916	82,822
5	2839K	4.3207e-06	1.0057	83,869
6	2863K	4.4041e-06	0.9981	80,557
7	2828K	4.6469e-06	0.9963	75,948
8	2827K	5.5363e-06	0.9983	64,122
9	2807K	3.8756e-06	0.9881	88,941
10	2829K	3.8821e-06	0.9935	90,199
11	2838K	4.6058e-06	0.9921	75,727
12	2852K	4.0835e-06	0.9915	85,266
13	2854K	4.5754e-06	0.9954	76,942
14	2856K	3.8793e-06	0.9990	91,672
15	2848K	3.9535e-06	0.9938	88,654
16	2863K	4.5575e-06	1.0029	78,891
17	2844K	4.4633e-06	0.9974	79,336
18	2767K	3.5683e-06	0.9962	98,878
19	2808K	5.5438e-06	0.9987	64,106
20	2742K	4.5901e-06	0.9883	75,140
21	2761K	3.7175e-06	0.9918	93,723
22	2766K	4.4798e-06	0.9900	77,363
23	2732K	5.0235e-06	0.9944	69,889
24	2746K	1.0155e-05	1.0194	37,016
25	2765K	5.2077e-06	0.9954	67,614
ave	2817K	4.7110e-06	0.9966	74,993

CIE 1976 u' data for tested units

$T_s = T_{air} = 55^{\circ}\text{C}$, $I_f = 200\text{mA}$; $T_s \geq 53^{\circ}\text{C}$ and $T_{air} \geq 50^{\circ}\text{C}$ in compliance with LM-80-08

	CCT (t=0)	0hrs	1000hrs	2000hrs	3000hrs	4000hrs	5000hrs	6000hrs	7000hrs	8000hrs	9000hrs
1	2846K	0.2553	0.2539	0.2539	0.2537	0.2535	0.2533	0.2530	0.2526	0.2529	0.2528
2	2842K	0.2552	0.2537	0.2538	0.2537	0.2534	0.2532	0.2530	0.2527	0.2525	0.2523
3	2863K	0.2541	0.2526	0.2525	0.2527	0.2524	0.2521	0.2519	0.2517	0.2518	0.2516
4	2856K	0.2550	0.2536	0.2535	0.2534	0.2532	0.2530	0.2527	0.2525	0.2522	0.2520
5	2839K	0.2551	0.2535	0.2536	0.2535	0.2533	0.2530	0.2528	0.2524	0.2529	0.2528
6	2863K	0.2543	0.2528	0.2526	0.2526	0.2525	0.2524	0.2526	0.2524	0.2521	0.2519
7	2828K	0.2557	0.2540	0.2538	0.2538	0.2537	0.2537	0.2537	0.2534	0.2534	0.2530
8	2827K	0.2556	0.2539	0.2538	0.2537	0.2535	0.2534	0.2532	0.2529	0.2534	0.2531
9	2807K	0.2565	0.2549	0.2549	0.2548	0.2546	0.2545	0.2543	0.2538	0.2539	0.2539
10	2829K	0.2555	0.2539	0.2535	0.2535	0.2532	0.2531	0.2530	0.2528	0.2523	0.2521
11	2838K	0.2548	0.2535	0.2532	0.2539	0.2536	0.2534	0.2531	0.2529	0.2532	0.2526
12	2852K	0.2544	0.2530	0.2526	0.2523	0.2521	0.2520	0.2517	0.2512	0.2519	0.2521
13	2854K	0.2547	0.2532	0.2529	0.2528	0.2526	0.2523	0.2520	0.2516	0.2517	0.2517
14	2856K	0.2539	0.2522	0.2521	0.2521	0.2519	0.2517	0.2513	0.2510	0.2509	0.2508
15	2848K	0.2543	0.2529	0.2526	0.2526	0.2525	0.2521	0.2519	0.2516	0.2514	0.2514
16	2863K	0.2547	0.2532	0.2530	0.2531	0.2529	0.2527	0.2523	0.2518	0.2517	0.2515
17	2844K	0.2548	0.2534	0.2532	0.2532	0.2531	0.2530	0.2525	0.2522	0.2519	0.2519
18	2767K	0.2578	0.2563	0.2561	0.2561	0.2560	0.2559	0.2557	0.2553	0.2547	0.2548
19	2808K	0.2571	0.2559	0.2554	0.2556	0.2553	0.2552	0.2551	0.2546	0.2536	0.2536
20	2742K	0.2594	0.2582	0.2578	0.2584	0.2581	0.2579	0.2575	0.2574	0.2568	0.2562
21	2761K	0.2591	0.2577	0.2574	0.2572	0.2570	0.2568	0.2561	0.2557	0.2552	0.2548
22	2766K	0.2587	0.2573	0.2572	0.2571	0.2570	0.2568	0.2564	0.2563	0.2566	0.2564
23	2732K	0.2604	0.2591	0.2588	0.2589	0.2587	0.2584	0.2581	0.2580	0.2580	0.2581
24	2746K	0.2600	0.2589	0.2585	0.2584	0.2581	0.2580	0.2577	0.2575	0.2571	0.2571
25	2765K	0.2589	0.2576	0.2574	0.2575	0.2573	0.2572	0.2571	0.2568	0.2564	0.2564

CIE 1976 v' data for tested units

$T_s = T_{air} = 55^{\circ}\text{C}$, $I_f = 200\text{mA}$; $T_s \geq 53^{\circ}\text{C}$ and $T_{air} \geq 50^{\circ}\text{C}$ in compliance with LM-80-08

	CCT (t=0)	0hrs	1000hrs	2000hrs	3000hrs	4000hrs	5000hrs	6000hrs	7000hrs	8000hrs	9000hrs
1	2846K	0.5294	0.5295	0.5290	0.5287	0.5285	0.5283	0.5280	0.5278	0.5274	0.5270
2	2842K	0.5306	0.5306	0.5302	0.5298	0.5296	0.5294	0.5291	0.5289	0.5285	0.5280
3	2863K	0.5313	0.5313	0.5309	0.5306	0.5305	0.5301	0.5299	0.5295	0.5294	0.5290
4	2856K	0.5285	0.5285	0.5281	0.5278	0.5275	0.5271	0.5269	0.5265	0.5263	0.5258
5	2839K	0.5316	0.5315	0.5311	0.5308	0.5306	0.5303	0.5301	0.5296	0.5296	0.5293
6	2863K	0.5302	0.5300	0.5297	0.5294	0.5293	0.5290	0.5290	0.5287	0.5284	0.5279
7	2828K	0.5309	0.5309	0.5304	0.5301	0.5300	0.5298	0.5295	0.5292	0.5290	0.5285
8	2827K	0.5317	0.5317	0.5313	0.5309	0.5307	0.5304	0.5302	0.5298	0.5299	0.5294
9	2807K	0.5320	0.5321	0.5317	0.5313	0.5311	0.5309	0.5307	0.5304	0.5302	0.5298
10	2829K	0.5317	0.5316	0.5311	0.5309	0.5306	0.5304	0.5301	0.5298	0.5295	0.5290
11	2838K	0.5330	0.5332	0.5327	0.5317	0.5315	0.5313	0.5309	0.5307	0.5311	0.5310
12	2852K	0.5321	0.5322	0.5317	0.5312	0.5310	0.5308	0.5306	0.5304	0.5297	0.5294
13	2854K	0.5303	0.5302	0.5298	0.5294	0.5291	0.5290	0.5287	0.5284	0.5275	0.5271
14	2856K	0.5334	0.5334	0.5330	0.5326	0.5323	0.5323	0.5320	0.5317	0.5309	0.5305
15	2848K	0.5335	0.5337	0.5332	0.5328	0.5325	0.5324	0.5321	0.5319	0.5310	0.5306
16	2863K	0.5284	0.5283	0.5280	0.5277	0.5274	0.5272	0.5269	0.5266	0.5257	0.5252
17	2844K	0.5317	0.5317	0.5314	0.5310	0.5308	0.5305	0.5303	0.5301	0.5292	0.5288
18	2767K	0.5347	0.5349	0.5343	0.5340	0.5338	0.5336	0.5334	0.5332	0.5323	0.5319
19	2808K	0.5288	0.5284	0.5281	0.5275	0.5275	0.5272	0.5269	0.5268	0.5257	0.5253
20	2742K	0.5327	0.5325	0.5322	0.5308	0.5306	0.5303	0.5300	0.5298	0.5299	0.5294
21	2761K	0.5297	0.5295	0.5291	0.5286	0.5283	0.5281	0.5278	0.5274	0.5264	0.5259
22	2766K	0.5306	0.5305	0.5301	0.5297	0.5294	0.5291	0.5290	0.5289	0.5280	0.5276
23	2732K	0.5303	0.5301	0.5298	0.5294	0.5291	0.5288	0.5287	0.5286	0.5277	0.5273
24	2746K	0.5289	0.5288	0.5282	0.5278	0.5276	0.5274	0.5271	0.5270	0.5260	0.5255
25	2765K	0.5296	0.5294	0.5291	0.5287	0.5284	0.5282	0.5281	0.5280	0.5271	0.5266

Delta u'v' data for tested units

$T_s = T_{air} = 55^{\circ}\text{C}$, $I_f = 200\text{mA}$; $T_s \geq 53^{\circ}\text{C}$ and $T_{air} \geq 50^{\circ}\text{C}$ in compliance with LM-80-08

	CCT (t=0)	0hrs	1000hrs	2000hrs	3000hrs	4000hrs	5000hrs	6000hrs	7000hrs	8000hrs	9000hrs
1	2846K	0.0000	0.0014	0.0015	0.0017	0.0020	0.0023	0.0027	0.0031	0.0031	0.0035
2	2842K	0.0000	0.0015	0.0015	0.0017	0.0021	0.0023	0.0027	0.0030	0.0034	0.0039
3	2863K	0.0000	0.0015	0.0016	0.0016	0.0019	0.0023	0.0026	0.0030	0.0030	0.0034
4	2856K	0.0000	0.0014	0.0016	0.0017	0.0021	0.0024	0.0028	0.0032	0.0036	0.0040
5	2839K	0.0000	0.0016	0.0016	0.0018	0.0021	0.0025	0.0027	0.0034	0.0030	0.0033
6	2863K	0.0000	0.0015	0.0018	0.0019	0.0020	0.0022	0.0021	0.0024	0.0028	0.0033
7	2828K	0.0000	0.0017	0.0020	0.0021	0.0022	0.0023	0.0024	0.0029	0.0030	0.0036
8	2827K	0.0000	0.0017	0.0018	0.0021	0.0023	0.0026	0.0028	0.0033	0.0028	0.0034
9	2807K	0.0000	0.0016	0.0016	0.0018	0.0021	0.0023	0.0026	0.0031	0.0032	0.0034
10	2829K	0.0000	0.0016	0.0021	0.0022	0.0025	0.0027	0.0030	0.0033	0.0039	0.0043
11	2838K	0.0000	0.0013	0.0016	0.0016	0.0019	0.0022	0.0027	0.0030	0.0025	0.0030
12	2852K	0.0000	0.0014	0.0018	0.0023	0.0025	0.0027	0.0031	0.0036	0.0035	0.0035
13	2854K	0.0000	0.0015	0.0019	0.0021	0.0024	0.0027	0.0031	0.0036	0.0041	0.0044
14	2856K	0.0000	0.0017	0.0018	0.0020	0.0023	0.0025	0.0030	0.0034	0.0039	0.0042
15	2848K	0.0000	0.0014	0.0017	0.0018	0.0021	0.0025	0.0028	0.0031	0.0038	0.0041
16	2863K	0.0000	0.0015	0.0017	0.0017	0.0021	0.0023	0.0028	0.0034	0.0040	0.0045
17	2844K	0.0000	0.0014	0.0016	0.0017	0.0019	0.0022	0.0027	0.0031	0.0038	0.0041
18	2767K	0.0000	0.0015	0.0017	0.0018	0.0020	0.0022	0.0025	0.0029	0.0039	0.0041
19	2808K	0.0000	0.0013	0.0018	0.0020	0.0022	0.0025	0.0028	0.0032	0.0047	0.0049
20	2742K	0.0000	0.0012	0.0017	0.0021	0.0025	0.0028	0.0033	0.0035	0.0038	0.0046
21	2761K	0.0000	0.0014	0.0018	0.0022	0.0025	0.0028	0.0036	0.0041	0.0051	0.0057
22	2766K	0.0000	0.0014	0.0016	0.0018	0.0021	0.0024	0.0028	0.0029	0.0033	0.0038
23	2732K	0.0000	0.0013	0.0017	0.0017	0.0021	0.0025	0.0028	0.0029	0.0035	0.0038
24	2746K	0.0000	0.0011	0.0017	0.0019	0.0023	0.0025	0.0029	0.0031	0.0041	0.0045
25	2765K	0.0000	0.0013	0.0016	0.0017	0.0020	0.0022	0.0023	0.0026	0.0035	0.0039

Forward Voltage [V] data for tested units

$T_s = T_{air} = 55^{\circ}\text{C}$, $I_f = 200\text{mA}$; $T_s \geq 53^{\circ}\text{C}$ and $T_{air} \geq 50^{\circ}\text{C}$ in compliance with LM-80-08

	CCT (t=0)	0hrs	1000hrs	2000hrs	3000hrs	4000hrs	5000hrs	6000hrs	7000hrs	8000hrs	9000hrs
1	2846K	6.477	6.440	6.427	6.444	6.443	6.445	6.440	6.501	6.447	6.464
2	2842K	6.198	6.191	6.178	6.189	6.190	6.188	6.185	6.213	6.183	6.197
3	2863K	6.360	6.322	6.306	6.321	6.313	6.324	6.315	6.370	6.311	6.322
4	2856K	6.427	6.396	6.388	6.397	6.392	6.391	6.394	6.415	6.390	6.396
5	2839K	6.355	6.316	6.313	6.325	6.321	6.328	6.319	6.359	6.317	6.325
6	2863K	6.152	6.130	6.125	6.137	6.136	6.136	6.130	6.154	6.130	6.137
7	2828K	6.161	6.147	6.143	6.151	6.152	6.145	6.145	6.169	6.158	6.150
8	2827K	6.172	6.160	6.162	6.167	6.164	6.161	6.169	6.190	6.165	6.176
9	2807K	6.136	6.115	6.114	6.118	6.117	6.112	6.115	6.295	6.126	6.124
10	2829K	6.383	6.355	6.350	6.352	6.355	6.353	6.350	6.370	6.349	6.363
11	2838K	6.188	6.173	6.170	6.172	6.173	6.168	6.168	6.186	6.178	6.178
12	2852K	6.168	6.157	6.156	6.150	6.153	6.153	6.152	6.177	6.154	6.154
13	2854K	6.496	6.449	6.444	6.455	6.454	6.452	6.454	6.490	6.453	6.460
14	2856K	6.169	6.155	6.153	6.156	6.155	6.157	6.152	6.175	6.165	6.161
15	2848K	6.162	6.151	6.144	6.148	6.145	6.151	6.144	6.167	6.154	6.151
16	2863K	6.297	6.262	6.257	6.265	6.261	6.264	6.262	6.288	6.264	6.260
17	2844K	6.166	6.154	6.149	6.155	6.149	6.155	6.149	6.173	6.157	6.154
18	2767K	6.158	6.153	6.150	6.153	6.148	6.157	6.150	6.164	6.159	6.153
19	2808K	6.647	6.634	6.603	6.594	6.634	6.626	6.634	6.647	6.619	6.612
20	2742K	6.396	6.368	6.369	6.366	6.364	6.367	6.364	6.391	6.365	6.371
21	2761K	6.586	6.559	6.551	6.560	6.566	6.565	6.881	6.590	6.561	6.561
22	2766K	6.524	6.490	6.488	6.488	6.492	6.490	6.488	6.513	6.488	6.493
23	2732K	6.412	6.390	6.391	6.395	6.388	6.403	6.387	6.449	6.393	6.396
24	2746K	6.736	6.686	6.681	6.680	6.705	6.702	6.703	6.722	6.706	6.700
25	2765K	6.450	6.418	6.419	6.428	6.427	6.422	6.419	6.442	6.428	6.440

Luminous Flux [lm] data for tested units

$T_s = T_{air} = 85^{\circ}C, I_f = 200mA; T_s \geq 83^{\circ}C$ and $T_{air} \geq 80^{\circ}C$ in compliance with LM-80-08

	CCT (t=0)	0hrs	1000hrs	2000hrs	3000hrs	4000hrs	5000hrs	6000hrs	7000hrs	8000hrs	9000hrs
1	2831K	137.500	136.300	135.500	134.600	133.700	133.100	132.400	131.800	131.100	130.000
2	2865K	136.000	135.300	134.500	133.600	133.000	132.200	131.900	131.100	130.700	130.000
3	2826K	137.900	136.700	136.000	135.000	134.200	133.700	133.200	132.600	132.000	131.000
4	2865K	131.400	129.700	129.000	128.200	127.500	126.900	126.600	126.100	125.400	124.400
5	2803K	134.200	133.600	132.800	132.100	131.500	130.900	130.200	129.700	129.000	127.900
6	2792K	135.800	135.200	134.400	133.900	133.000	132.200	131.100	130.400	129.800	128.700
7	2859K	132.400	131.700	131.000	130.200	129.200	128.500	128.200	127.700	127.100	126.300
8	2852K	135.800	134.900	133.100	132.800	132.100	131.600	130.400	129.800	129.000	127.900
9	2842K	139.500	138.300	137.600	136.500	135.600	134.700	134.200	133.800	133.000	132.000
10	2865K	135.100	134.500	133.700	132.600	131.800	131.000	129.900	129.300	128.400	127.400
11	2839K	134.600	133.600	132.900	132.100	131.400	130.500	129.800	129.100	128.100	127.200
12	2861K	135.200	134.800	134.400	132.700	132.200	131.500	131.300	130.900	129.900	128.700
13	2867K	136.400	135.400	134.200	133.800	133.100	132.000	130.900	130.400	129.500	128.300
14	2855K	133.000	132.300	132.100	131.300	130.700	129.700	129.000	128.400	127.400	126.100
15	2863K	134.500	133.600	132.600	131.100	130.100	129.400	129.000	128.600	127.500	126.600
16	2797K	133.100	133.100	132.100	130.600	129.600	129.000	128.700	128.100	127.200	126.500
17	2831K	129.600	129.800	129.400	128.200	127.400	126.600	126.000	125.500	124.700	123.600
18	2788K	125.700	123.500	122.800	122.200	121.200	120.500	119.800	119.300	118.300	117.200
19	2787K	120.800	120.500	120.000	118.100	117.400	116.700	115.900	115.500	114.600	113.600
20	2713K	124.800	123.700	122.500	121.600	120.400	119.800	119.500	118.700	117.900	117.200
21	2827K	122.400	121.500	120.200	120.100	118.800	118.200	117.900	117.200	116.200	115.300
22	2804K	130.200	129.600	128.900	128.400	127.000	126.200	125.900	125.500	124.400	123.300
23	2751K	125.300	124.200	123.300	122.900	122.200	121.300	120.600	120.300	119.200	118.400
24	2829K	132.400	131.200	130.100	129.500	128.500	127.600	126.600	126.200	124.700	124.000
25	2757K	127.100	125.300	124.900	123.900	123.200	122.300	121.600	121.200	119.900	118.700

Normalized Luminous Flux data for tested units

$T_s = T_{air} = 85^{\circ}C, I_f = 200mA; T_s \geq 83^{\circ}C$ and $T_{air} \geq 80^{\circ}C$ in compliance with LM-80-08

	CCT (t=0)	0hrs	1000hrs	2000hrs	3000hrs	4000hrs	5000hrs	6000hrs	7000hrs	8000hrs	9000hrs
1	2831K	1.0000	0.9913	0.9855	0.9789	0.9724	0.9680	0.9629	0.9585	0.9535	0.9455
2	2865K	1.0000	0.9949	0.9890	0.9824	0.9779	0.9721	0.9699	0.9640	0.9610	0.9559
3	2826K	1.0000	0.9913	0.9862	0.9790	0.9732	0.9695	0.9659	0.9616	0.9572	0.9500
4	2865K	1.0000	0.9871	0.9817	0.9756	0.9703	0.9658	0.9635	0.9597	0.9543	0.9467
5	2803K	1.0000	0.9955	0.9896	0.9844	0.9799	0.9754	0.9702	0.9665	0.9613	0.9531
6	2792K	1.0000	0.9956	0.9897	0.9860	0.9794	0.9735	0.9654	0.9602	0.9558	0.9477
7	2859K	1.0000	0.9947	0.9894	0.9834	0.9758	0.9705	0.9683	0.9645	0.9600	0.9539
8	2852K	1.0000	0.9934	0.9801	0.9779	0.9728	0.9691	0.9602	0.9558	0.9499	0.9418
9	2842K	1.0000	0.9914	0.9864	0.9785	0.9720	0.9656	0.9620	0.9591	0.9534	0.9462
10	2865K	1.0000	0.9956	0.9896	0.9815	0.9756	0.9697	0.9615	0.9571	0.9504	0.9430
11	2839K	1.0000	0.9926	0.9874	0.9814	0.9762	0.9695	0.9643	0.9591	0.9517	0.9450
12	2861K	1.0000	0.9970	0.9941	0.9815	0.9778	0.9726	0.9712	0.9682	0.9608	0.9519
13	2867K	1.0000	0.9927	0.9839	0.9809	0.9758	0.9677	0.9597	0.9560	0.9494	0.9406
14	2855K	1.0000	0.9947	0.9932	0.9872	0.9827	0.9752	0.9699	0.9654	0.9579	0.9481
15	2863K	1.0000	0.9933	0.9859	0.9747	0.9673	0.9621	0.9591	0.9561	0.9480	0.9413
16	2797K	1.0000	1.0000	0.9925	0.9812	0.9737	0.9692	0.9669	0.9624	0.9557	0.9504
17	2831K	1.0000	1.0015	0.9985	0.9892	0.9830	0.9769	0.9722	0.9684	0.9622	0.9537
18	2788K	1.0000	0.9825	0.9769	0.9722	0.9642	0.9586	0.9531	0.9491	0.9411	0.9324
19	2787K	1.0000	0.9975	0.9934	0.9776	0.9719	0.9661	0.9594	0.9561	0.9487	0.9404
20	2713K	1.0000	0.9912	0.9816	0.9744	0.9647	0.9599	0.9575	0.9511	0.9447	0.9391
21	2827K	1.0000	0.9926	0.9820	0.9812	0.9706	0.9657	0.9632	0.9575	0.9493	0.9420
22	2804K	1.0000	0.9954	0.9900	0.9862	0.9754	0.9693	0.9670	0.9639	0.9555	0.9470
23	2751K	1.0000	0.9912	0.9840	0.9808	0.9753	0.9681	0.9625	0.9601	0.9513	0.9449
24	2829K	1.0000	0.9909	0.9826	0.9781	0.9705	0.9637	0.9562	0.9532	0.9418	0.9366
25	2757K	1.0000	0.9858	0.9827	0.9748	0.9693	0.9622	0.9567	0.9536	0.9434	0.9339

TM-21 Extrapolation of Luminous Flux data for tested units

$T_s = T_{air} = 85^{\circ}\text{C}$, $I_f = 200\text{mA}$; $T_s \geq 83^{\circ}\text{C}$ and $T_{air} \geq 80^{\circ}\text{C}$ in compliance with LM-80-08

	CCT (t=0)	alpha	B	L70
1	2831K	5.4367e-06	0.9946	64,612
2	2865K	4.4112e-06	0.9949	79,694
3	2826K	4.6735e-06	0.9926	74,721
4	2865K	4.6486e-06	0.9895	74,449
5	2803K	5.3286e-06	1.0018	67,268
6	2792K	6.4183e-06	1.0047	56,296
7	2859K	4.2937e-06	0.9928	81,388
8	2852K	6.4579e-06	0.9993	55,121
9	2842K	5.0179e-06	0.9915	69,384
10	2865K	6.7011e-06	1.0022	53,552
11	2839K	6.3863e-06	1.0017	56,111
12	2861K	4.9696e-06	0.9988	71,529
13	2867K	6.9954e-06	1.0027	51,375
14	2855K	6.7853e-06	1.0101	54,040
15	2863K	5.2525e-06	0.9888	65,759
16	2797K	4.7966e-06	0.9935	73,006
17	2831K	5.7356e-06	1.0062	63,258
18	2788K	6.4932e-06	0.9906	53,481
19	2787K	6.3557e-06	0.9974	55,709
20	2713K	5.4105e-06	0.9869	63,490
21	2827K	5.9049e-06	0.9955	59,639
22	2804K	5.5461e-06	0.9983	64,006
23	2751K	6.0810e-06	0.9990	58,494
24	2829K	7.1534e-06	0.9990	49,720
25	2757K	7.1086e-06	0.9982	49,920
ave	2822K	5.7725e-06	0.9972	61,304

CIE 1976 u' data for tested units

$T_s = T_{air} = 85^{\circ}\text{C}$, $I_f = 200\text{mA}$; $T_s \geq 83^{\circ}\text{C}$ and $T_{air} \geq 80^{\circ}\text{C}$ in compliance with LM-80-08

	CCT (t=0)	0hrs	1000hrs	2000hrs	3000hrs	4000hrs	5000hrs	6000hrs	7000hrs	8000hrs	9000hrs
1	2831K	0.2551	0.2537	0.2537	0.2537	0.2534	0.2532	0.2527	0.2522	0.2521	0.2521
2	2865K	0.2545	0.2528	0.2527	0.2529	0.2527	0.2525	0.2517	0.2513	0.2509	0.2507
3	2826K	0.2554	0.2538	0.2536	0.2535	0.2535	0.2533	0.2527	0.2524	0.2516	0.2515
4	2865K	0.2537	0.2523	0.2522	0.2521	0.2521	0.2519	0.2512	0.2509	0.2502	0.2500
5	2803K	0.2564	0.2550	0.2548	0.2548	0.2547	0.2546	0.2541	0.2539	0.2532	0.2530
6	2792K	0.2565	0.2550	0.2548	0.2543	0.2541	0.2539	0.2538	0.2535	0.2529	0.2526
7	2859K	0.2544	0.2525	0.2523	0.2520	0.2518	0.2516	0.2515	0.2511	0.2509	0.2503
8	2852K	0.2545	0.2530	0.2529	0.2526	0.2523	0.2523	0.2519	0.2517	0.2510	0.2512
9	2842K	0.2547	0.2530	0.2528	0.2525	0.2522	0.2520	0.2518	0.2516	0.2509	0.2508
10	2865K	0.2544	0.2528	0.2526	0.2523	0.2522	0.2520	0.2517	0.2514	0.2507	0.2499
11	2839K	0.2552	0.2536	0.2535	0.2530	0.2529	0.2527	0.2524	0.2522	0.2518	0.2512
12	2861K	0.2542	0.2525	0.2525	0.2527	0.2524	0.2522	0.2516	0.2511	0.2503	0.2498
13	2867K	0.2539	0.2519	0.2519	0.2516	0.2515	0.2513	0.2510	0.2507	0.2505	0.2500
14	2855K	0.2552	0.2534	0.2534	0.2530	0.2530	0.2529	0.2523	0.2519	0.2516	0.2512
15	2863K	0.2546	0.2532	0.2529	0.2527	0.2526	0.2523	0.2521	0.2518	0.2515	0.2508
16	2797K	0.2568	0.2554	0.2553	0.2551	0.2548	0.2546	0.2544	0.2541	0.2540	0.2534
17	2831K	0.2563	0.2548	0.2548	0.2545	0.2543	0.2540	0.2538	0.2536	0.2535	0.2531
18	2788K	0.2585	0.2572	0.2572	0.2567	0.2564	0.2562	0.2559	0.2557	0.2554	0.2551
19	2787K	0.2578	0.2566	0.2565	0.2560	0.2558	0.2557	0.2553	0.2550	0.2550	0.2548
20	2713K	0.2608	0.2593	0.2592	0.2587	0.2584	0.2580	0.2577	0.2573	0.2571	0.2569
21	2827K	0.2569	0.2555	0.2554	0.2553	0.2550	0.2549	0.2548	0.2542	0.2533	0.2531
22	2804K	0.2574	0.2559	0.2558	0.2554	0.2552	0.2551	0.2543	0.2543	0.2537	0.2536
23	2751K	0.2588	0.2573	0.2572	0.2568	0.2567	0.2565	0.2557	0.2553	0.2552	0.2550
24	2829K	0.2564	0.2550	0.2550	0.2545	0.2543	0.2541	0.2536	0.2531	0.2532	0.2529
25	2757K	0.2596	0.2581	0.2580	0.2577	0.2575	0.2572	0.2570	0.2567	0.2561	0.2559

CIE 1976 v' data for tested units

$T_s = T_{air} = 85^{\circ}\text{C}$, $I_f = 200\text{mA}$; $T_s \geq 83^{\circ}\text{C}$ and $T_{air} \geq 80^{\circ}\text{C}$ in compliance with LM-80-08

	CCT (t=0)	0hrs	1000hrs	2000hrs	3000hrs	4000hrs	5000hrs	6000hrs	7000hrs	8000hrs	9000hrs
1	2831K	0.5331	0.5334	0.5329	0.5325	0.5322	0.5320	0.5320	0.5316	0.5309	0.5307
2	2865K	0.5291	0.5290	0.5287	0.5283	0.5280	0.5278	0.5277	0.5273	0.5264	0.5261
3	2826K	0.5328	0.5329	0.5324	0.5321	0.5317	0.5315	0.5315	0.5313	0.5306	0.5301
4	2865K	0.5323	0.5324	0.5320	0.5316	0.5313	0.5311	0.5310	0.5308	0.5301	0.5295
5	2803K	0.5334	0.5337	0.5332	0.5328	0.5325	0.5323	0.5324	0.5321	0.5316	0.5310
6	2792K	0.5349	0.5351	0.5346	0.5341	0.5337	0.5335	0.5336	0.5334	0.5329	0.5322
7	2859K	0.5308	0.5306	0.5303	0.5298	0.5295	0.5292	0.5293	0.5290	0.5286	0.5280
8	2852K	0.5316	0.5318	0.5313	0.5309	0.5305	0.5303	0.5304	0.5301	0.5288	0.5289
9	2842K	0.5327	0.5326	0.5322	0.5318	0.5314	0.5312	0.5313	0.5311	0.5298	0.5296
10	2865K	0.5292	0.5292	0.5288	0.5283	0.5279	0.5277	0.5277	0.5274	0.5269	0.5261
11	2839K	0.5312	0.5313	0.5310	0.5305	0.5302	0.5300	0.5300	0.5297	0.5293	0.5287
12	2861K	0.5309	0.5311	0.5309	0.5301	0.5300	0.5298	0.5299	0.5296	0.5291	0.5286
13	2867K	0.5312	0.5310	0.5307	0.5302	0.5299	0.5296	0.5296	0.5291	0.5290	0.5286
14	2855K	0.5281	0.5279	0.5276	0.5272	0.5269	0.5267	0.5265	0.5261	0.5258	0.5253
15	2863K	0.5291	0.5293	0.5289	0.5285	0.5282	0.5280	0.5280	0.5275	0.5272	0.5267
16	2797K	0.5329	0.5330	0.5327	0.5322	0.5320	0.5318	0.5317	0.5313	0.5311	0.5307
17	2831K	0.5278	0.5277	0.5274	0.5271	0.5268	0.5265	0.5264	0.5261	0.5257	0.5253
18	2788K	0.5266	0.5265	0.5262	0.5258	0.5253	0.5252	0.5251	0.5247	0.5244	0.5240
19	2787K	0.5303	0.5302	0.5299	0.5295	0.5291	0.5290	0.5289	0.5284	0.5282	0.5279
20	2713K	0.5328	0.5328	0.5323	0.5318	0.5314	0.5313	0.5312	0.5308	0.5305	0.5301
21	2827K	0.5256	0.5254	0.5251	0.5248	0.5243	0.5241	0.5240	0.5238	0.5230	0.5227
22	2804K	0.5284	0.5283	0.5280	0.5275	0.5270	0.5267	0.5267	0.5264	0.5259	0.5256
23	2751K	0.5334	0.5334	0.5329	0.5324	0.5322	0.5318	0.5317	0.5313	0.5311	0.5307
24	2829K	0.5277	0.5275	0.5273	0.5268	0.5264	0.5262	0.5261	0.5257	0.5254	0.5250
25	2757K	0.5284	0.5282	0.5278	0.5274	0.5270	0.5267	0.5267	0.5264	0.5258	0.5255

Delta u'v' data for tested units

$T_s = T_{air} = 85^{\circ}\text{C}$, $I_f = 200\text{mA}$; $T_s \geq 83^{\circ}\text{C}$ and $T_{air} \geq 80^{\circ}\text{C}$ in compliance with LM-80-08

	CCT (t=0)	0hrs	1000hrs	2000hrs	3000hrs	4000hrs	5000hrs	6000hrs	7000hrs	8000hrs	9000hrs
1	2831K	0.0000	0.0014	0.0014	0.0015	0.0019	0.0022	0.0026	0.0033	0.0037	0.0038
2	2865K	0.0000	0.0017	0.0018	0.0018	0.0021	0.0024	0.0031	0.0037	0.0045	0.0048
3	2826K	0.0000	0.0016	0.0018	0.0020	0.0022	0.0025	0.0030	0.0034	0.0044	0.0047
4	2865K	0.0000	0.0014	0.0015	0.0017	0.0019	0.0022	0.0028	0.0032	0.0041	0.0046
5	2803K	0.0000	0.0014	0.0016	0.0017	0.0019	0.0021	0.0025	0.0028	0.0037	0.0042
6	2792K	0.0000	0.0015	0.0017	0.0023	0.0027	0.0030	0.0030	0.0034	0.0041	0.0047
7	2859K	0.0000	0.0019	0.0022	0.0026	0.0029	0.0032	0.0033	0.0038	0.0041	0.0050
8	2852K	0.0000	0.0015	0.0016	0.0020	0.0025	0.0026	0.0029	0.0032	0.0045	0.0043
9	2842K	0.0000	0.0017	0.0020	0.0024	0.0028	0.0031	0.0032	0.0035	0.0048	0.0050
10	2865K	0.0000	0.0016	0.0018	0.0023	0.0026	0.0028	0.0031	0.0035	0.0044	0.0055
11	2839K	0.0000	0.0016	0.0017	0.0023	0.0025	0.0028	0.0030	0.0034	0.0039	0.0047
12	2861K	0.0000	0.0017	0.0017	0.0017	0.0020	0.0023	0.0028	0.0034	0.0043	0.0050
13	2867K	0.0000	0.0020	0.0021	0.0025	0.0027	0.0031	0.0033	0.0038	0.0040	0.0047
14	2855K	0.0000	0.0018	0.0019	0.0024	0.0025	0.0027	0.0033	0.0039	0.0043	0.0049
15	2863K	0.0000	0.0014	0.0017	0.0020	0.0022	0.0025	0.0027	0.0032	0.0036	0.0045
16	2797K	0.0000	0.0014	0.0015	0.0018	0.0022	0.0025	0.0027	0.0031	0.0033	0.0040
17	2831K	0.0000	0.0015	0.0016	0.0019	0.0022	0.0026	0.0029	0.0032	0.0035	0.0041
18	2788K	0.0000	0.0013	0.0014	0.0020	0.0025	0.0027	0.0030	0.0034	0.0038	0.0043
19	2787K	0.0000	0.0012	0.0014	0.0020	0.0023	0.0025	0.0029	0.0034	0.0035	0.0038
20	2713K	0.0000	0.0015	0.0017	0.0023	0.0028	0.0032	0.0035	0.0040	0.0044	0.0047
21	2827K	0.0000	0.0014	0.0016	0.0018	0.0023	0.0025	0.0026	0.0032	0.0044	0.0048
22	2804K	0.0000	0.0015	0.0016	0.0022	0.0026	0.0029	0.0035	0.0037	0.0045	0.0047
23	2751K	0.0000	0.0015	0.0017	0.0022	0.0024	0.0028	0.0035	0.0041	0.0043	0.0047
24	2829K	0.0000	0.0014	0.0015	0.0021	0.0025	0.0027	0.0032	0.0039	0.0039	0.0044
25	2757K	0.0000	0.0015	0.0017	0.0021	0.0025	0.0029	0.0031	0.0035	0.0044	0.0047

Forward Voltage [V] data for tested units

$T_s = T_{air} = 85^{\circ}\text{C}$, $I_f = 200\text{mA}$; $T_s \geq 83^{\circ}\text{C}$ and $T_{air} \geq 80^{\circ}\text{C}$ in compliance with LM-80-08

	CCT (t=0)	0hrs	1000hrs	2000hrs	3000hrs	4000hrs	5000hrs	6000hrs	7000hrs	8000hrs	9000hrs
1	2831K	6.168	6.156	6.155	6.156	6.161	6.154	6.185	6.191	6.165	6.181
2	2865K	6.346	6.316	6.317	6.314	6.313	6.319	6.358	6.513	6.318	6.373
3	2826K	6.169	6.155	6.168	6.159	6.159	6.161	6.185	6.174	6.157	6.198
4	2865K	6.214	6.201	6.204	6.203	6.204	6.199	6.212	6.212	6.200	6.237
5	2803K	6.164	6.150	6.147	6.150	6.149	6.155	6.166	6.172	6.157	6.208
6	2792K	6.142	6.128	6.124	6.129	6.120	6.129	6.149	6.141	6.131	6.135
7	2859K	6.367	6.329	6.325	6.328	6.322	6.324	6.354	6.358	6.154	6.336
8	2852K	6.155	6.142	6.137	6.143	6.142	6.139	6.165	6.162	6.154	6.143
9	2842K	6.120	6.100	6.099	6.101	6.101	6.096	6.117	6.116	6.105	6.109
10	2865K	6.180	6.167	6.163	6.166	6.155	6.158	6.179	6.186	6.177	6.165
11	2839K	6.160	6.152	6.151	6.152	6.153	6.155	6.172	6.173	6.166	6.159
12	2861K	6.173	6.155	6.152	6.155	6.169	6.158	6.176	6.178	6.174	6.155
13	2867K	6.442	6.405	6.403	6.407	6.426	6.406	6.441	6.440	6.415	6.412
14	2855K	6.145	6.129	6.127	6.127	6.141	6.123	6.142	6.145	6.127	6.125
15	2863K	6.212	6.205	6.202	6.202	6.219	6.200	6.222	6.226	6.216	6.212
16	2797K	6.186	6.180	6.180	6.180	6.191	6.183	6.208	6.203	6.187	6.183
17	2831K	6.482	6.436	6.432	6.444	6.450	6.430	6.466	6.465	6.437	6.439
18	2788K	6.634	6.624	6.615	6.625	6.639	6.613	6.642	6.644	6.621	6.644
19	2787K	6.497	6.447	6.447	6.453	6.469	6.451	6.480	6.473	6.459	6.472
20	2713K	6.931	6.878	6.871	6.879	6.881	6.875	6.894	6.885	6.882	6.889
21	2827K	6.636	6.623	6.618	6.632	6.641	6.632	6.645	6.654	6.623	6.636
22	2804K	6.459	6.424	6.423	6.438	6.443	6.428	6.453	6.450	6.430	6.457
23	2751K	6.386	6.367	6.360	6.371	6.378	6.366	6.387	6.379	6.369	6.380
24	2829K	6.495	6.459	6.459	6.468	6.478	6.473	6.491	6.482	6.466	6.490
25	2757K	6.755	6.737	6.729	6.751	6.760	6.735	6.775	7.043	6.738	6.785

Luminous Flux [lm] data for tested units

$T_s = T_{air} = 105^{\circ}\text{C}$, $I_f = 200\text{mA}$; $T_s \geq 103^{\circ}\text{C}$ and $T_{air} \geq 100^{\circ}\text{C}$ in compliance with LM-80-08

	CCT (t=0)	0hrs	1000hrs	2000hrs	3000hrs	4000hrs	5000hrs	6000hrs	7000hrs	8000hrs	9000hrs
1	2802K	136.900	135.400	134.300	133.400	132.500	131.900	131.100	130.500	129.200	127.800
2	2820K	132.800	132.100	131.200	130.100	129.200	128.400	127.800	127.400	126.100	124.800
3	2842K	137.200	134.100	133.200	132.800	132.000	131.400	130.800	130.200	129.200	128.200
4	2846K	135.500	134.400	133.200	132.500	131.700	131.200	130.400	129.900	128.700	127.300
5	2790K	135.400	135.000	133.900	133.200	132.500	131.800	130.400	129.700	126.900	125.600
6	2799K	135.200	134.600	133.200	132.500	131.600	130.800	130.000	129.400	128.300	127.200
7	2869K	137.400	136.000	135.100	134.400	133.200	132.300	131.500	130.700	129.400	128.200
8	2858K	131.600	131.000	130.000	129.300	128.300	127.400	126.800	125.900	124.600	123.500
9	2810K	132.700	131.400	130.000	129.200	128.400	127.800	127.000	126.500	125.100	124.000
10	2824K	134.900	134.100	132.600	131.700	130.600	129.800	129.200	128.600	127.000	125.700
11	2865K	135.300	134.100	132.700	130.700	129.700	129.200	128.400	127.900	126.700	125.500
12	2850K	138.000	136.900	135.200	134.300	133.400	132.900	131.600	131.100	130.000	129.000
13	2868K	136.300	135.400	134.000	133.200	132.300	131.700	130.800	130.400	129.000	128.000
14	2820K	134.900	133.900	132.100	131.600	131.000	130.300	129.100	128.400	127.200	126.000
15	2839K	129.700	129.400	127.700	127.400	126.600	125.800	125.200	124.600	123.400	122.100
16	2750K	134.600	133.900	132.400	131.900	131.000	129.800	129.400	128.900	128.100	127.000
17	2781K	123.600	122.500	121.300	121.000	120.200	119.500	118.200	117.600	116.700	115.500
18	2690K	121.500	120.400	119.100	118.400	117.600	116.800	116.000	115.500	114.300	113.100
19	2726K	130.900	129.000	127.000	126.400	125.600	124.500	123.800	123.000	121.700	120.700
20	2761K	127.400	126.300	124.500	123.500	122.600	121.800	120.900	120.300	119.300	118.400
21	2813K	129.600	128.900	127.100	126.200	125.000	124.500	123.800	123.300	122.400	121.200
22	2838K	115.400	114.700	113.400	113.100	112.400	111.800	110.500	110.200	109.600	108.600
23	2770K	127.200	125.700	124.200	123.900	123.200	122.100	121.800	121.300	120.400	119.400
24	2760K	127.900	125.700	124.400	123.500	122.700	121.600	120.800	120.400	119.400	118.300
25	2770K	124.700	123.400	122.300	121.800	120.700	119.700	119.100	118.700	117.900	116.700

Normalized Luminous Flux data for tested units

$T_s = T_{air} = 105^{\circ}\text{C}$, $I_f = 200\text{mA}$; $T_s \geq 103^{\circ}\text{C}$ and $T_{air} \geq 100^{\circ}\text{C}$ in compliance with LM-80-08

	CCT (t=0)	0hrs	1000hrs	2000hrs	3000hrs	4000hrs	5000hrs	6000hrs	7000hrs	8000hrs	9000hrs
1	2802K	1.0000	0.9890	0.9810	0.9744	0.9679	0.9635	0.9576	0.9533	0.9438	0.9335
2	2820K	1.0000	0.9947	0.9880	0.9797	0.9729	0.9669	0.9623	0.9593	0.9495	0.9398
3	2842K	1.0000	0.9774	0.9708	0.9679	0.9621	0.9577	0.9534	0.9490	0.9417	0.9344
4	2846K	1.0000	0.9919	0.9830	0.9779	0.9720	0.9683	0.9624	0.9587	0.9498	0.9395
5	2790K	1.0000	0.9970	0.9889	0.9838	0.9786	0.9734	0.9631	0.9579	0.9372	0.9276
6	2799K	1.0000	0.9956	0.9852	0.9800	0.9734	0.9675	0.9615	0.9571	0.9490	0.9408
7	2869K	1.0000	0.9898	0.9833	0.9782	0.9694	0.9629	0.9571	0.9512	0.9418	0.9330
8	2858K	1.0000	0.9954	0.9878	0.9825	0.9749	0.9681	0.9635	0.9567	0.9468	0.9384
9	2810K	1.0000	0.9902	0.9797	0.9736	0.9676	0.9631	0.9570	0.9533	0.9427	0.9344
10	2824K	1.0000	0.9941	0.9830	0.9763	0.9681	0.9622	0.9577	0.9533	0.9414	0.9318
11	2865K	1.0000	0.9911	0.9808	0.9660	0.9586	0.9549	0.9490	0.9453	0.9364	0.9276
12	2850K	1.0000	0.9920	0.9797	0.9732	0.9667	0.9630	0.9536	0.9500	0.9420	0.9348
13	2868K	1.0000	0.9934	0.9831	0.9773	0.9707	0.9663	0.9596	0.9567	0.9464	0.9391
14	2820K	1.0000	0.9926	0.9792	0.9755	0.9711	0.9659	0.9570	0.9518	0.9429	0.9340
15	2839K	1.0000	0.9977	0.9846	0.9823	0.9761	0.9699	0.9653	0.9607	0.9514	0.9414
16	2750K	1.0000	0.9948	0.9837	0.9799	0.9733	0.9643	0.9614	0.9577	0.9517	0.9435
17	2781K	1.0000	0.9911	0.9814	0.9790	0.9725	0.9668	0.9563	0.9515	0.9442	0.9345
18	2690K	1.0000	0.9909	0.9802	0.9745	0.9679	0.9613	0.9547	0.9506	0.9407	0.9309
19	2726K	1.0000	0.9855	0.9702	0.9656	0.9595	0.9511	0.9458	0.9396	0.9297	0.9221
20	2761K	1.0000	0.9914	0.9772	0.9694	0.9623	0.9560	0.9490	0.9443	0.9364	0.9294
21	2813K	1.0000	0.9946	0.9807	0.9738	0.9645	0.9606	0.9552	0.9514	0.9444	0.9352
22	2838K	1.0000	0.9939	0.9827	0.9801	0.9740	0.9688	0.9575	0.9549	0.9497	0.9411
23	2770K	1.0000	0.9882	0.9764	0.9741	0.9686	0.9599	0.9575	0.9536	0.9465	0.9387
24	2760K	1.0000	0.9828	0.9726	0.9656	0.9593	0.9507	0.9445	0.9414	0.9335	0.9249
25	2770K	1.0000	0.9896	0.9808	0.9767	0.9679	0.9599	0.9551	0.9519	0.9455	0.9358

TM-21 Extrapolation of Luminous Flux data for tested units

$T_s = T_{air} = 105^{\circ}\text{C}$, $I_f = 200\text{mA}$; $T_s \geq 103^{\circ}\text{C}$ and $T_{air} \geq 100^{\circ}\text{C}$ in compliance with LM-80-08

	CCT (t=0)	alpha	B	L70
1	2802K	7.0633e-06	0.9980	50,208
2	2820K	6.5887e-06	1.0003	54,184
3	2842K	5.7515e-06	0.9858	59,534
4	2846K	6.6131e-06	1.0005	54,003
5	2790K	1.1041e-05	1.0273	34,740
6	2799K	6.6444e-06	1.0004	53,746
7	2869K	7.5398e-06	1.0003	47,350
8	2858K	7.5555e-06	1.0062	48,028
9	2810K	6.9242e-06	0.9968	51,052
10	2824K	7.4652e-06	0.9997	47,739
11	2865K	6.4889e-06	0.9860	52,789
12	2850K	6.7912e-06	0.9946	51,719
13	2868K	6.5833e-06	0.9982	53,908
14	2820K	7.7786e-06	1.0032	46,260
15	2839K	6.9586e-06	1.0052	52,001
16	2750K	5.6707e-06	0.9946	61,941
17	2781K	7.8757e-06	1.0043	45,835
18	2690K	7.5518e-06	0.9988	47,070
19	2726K	7.8198e-06	0.9903	44,365
20	2761K	6.8995e-06	0.9896	50,175
21	2813K	5.9840e-06	0.9896	57,859
22	2838K	6.6944e-06	1.0002	53,311
23	2770K	5.7950e-06	0.9907	59,939
24	2760K	6.8767e-06	0.9854	49,731
25	2770K	6.2094e-06	0.9919	56,126
ave	2806K	7.0063e-06	0.9975	50,549

CIE 1976 u' data for tested units

$T_s = T_{air} = 105^{\circ}\text{C}$, $I_f = 200\text{mA}$; $T_s \geq 103^{\circ}\text{C}$ and $T_{air} \geq 100^{\circ}\text{C}$ in compliance with LM-80-08

	CCT (t=0)	0hrs	1000hrs	2000hrs	3000hrs	4000hrs	5000hrs	6000hrs	7000hrs	8000hrs	9000hrs
1	2802K	0.2565	0.2549	0.2545	0.2544	0.2542	0.2540	0.2538	0.2536	0.2535	0.2535
2	2820K	0.2561	0.2545	0.2541	0.2541	0.2539	0.2536	0.2534	0.2531	0.2532	0.2533
3	2842K	0.2548	0.2524	0.2518	0.2518	0.2515	0.2512	0.2514	0.2510	0.2504	0.2503
4	2846K	0.2546	0.2530	0.2525	0.2526	0.2525	0.2523	0.2520	0.2517	0.2517	0.2516
5	2790K	0.2570	0.2550	0.2546	0.2546	0.2545	0.2542	0.2537	0.2534	0.2533	0.2531
6	2799K	0.2566	0.2551	0.2548	0.2548	0.2547	0.2544	0.2543	0.2539	0.2539	0.2537
7	2869K	0.2544	0.2529	0.2526	0.2526	0.2524	0.2521	0.2519	0.2515	0.2514	0.2516
8	2858K	0.2540	0.2522	0.2519	0.2519	0.2518	0.2516	0.2513	0.2509	0.2507	0.2506
9	2810K	0.2561	0.2543	0.2539	0.2539	0.2539	0.2536	0.2535	0.2530	0.2529	0.2529
10	2824K	0.2551	0.2537	0.2533	0.2534	0.2532	0.2529	0.2528	0.2524	0.2519	0.2517
11	2865K	0.2541	0.2527	0.2524	0.2523	0.2520	0.2517	0.2516	0.2513	0.2509	0.2507
12	2850K	0.2550	0.2536	0.2532	0.2538	0.2535	0.2533	0.2522	0.2519	0.2515	0.2513
13	2868K	0.2546	0.2529	0.2525	0.2524	0.2521	0.2518	0.2517	0.2513	0.2509	0.2507
14	2820K	0.2557	0.2543	0.2539	0.2540	0.2537	0.2535	0.2533	0.2529	0.2527	0.2525
15	2839K	0.2551	0.2534	0.2532	0.2532	0.2531	0.2527	0.2524	0.2522	0.2517	0.2514
16	2750K	0.2592	0.2577	0.2573	0.2573	0.2571	0.2568	0.2566	0.2564	0.2560	0.2555
17	2781K	0.2582	0.2566	0.2563	0.2561	0.2561	0.2557	0.2555	0.2553	0.2549	0.2544
18	2690K	0.2620	0.2605	0.2602	0.2602	0.2600	0.2596	0.2595	0.2592	0.2590	0.2585
19	2726K	0.2604	0.2587	0.2583	0.2580	0.2577	0.2576	0.2575	0.2573	0.2570	0.2566
20	2761K	0.2592	0.2577	0.2574	0.2569	0.2567	0.2563	0.2561	0.2554	0.2553	0.2549
21	2813K	0.2570	0.2551	0.2548	0.2547	0.2544	0.2541	0.2540	0.2537	0.2536	0.2531
22	2838K	0.2562	0.2546	0.2542	0.2541	0.2540	0.2537	0.2534	0.2532	0.2530	0.2526
23	2770K	0.2584	0.2569	0.2566	0.2566	0.2564	0.2562	0.2560	0.2557	0.2555	0.2551
24	2760K	0.2591	0.2576	0.2571	0.2570	0.2567	0.2565	0.2564	0.2558	0.2558	0.2552
25	2770K	0.2587	0.2570	0.2568	0.2567	0.2566	0.2563	0.2560	0.2555	0.2554	0.2551

CIE 1976 v' data for tested units

$T_s = T_{air} = 105^{\circ}\text{C}$, $I_f = 200\text{mA}$; $T_s \geq 103^{\circ}\text{C}$ and $T_{air} \geq 100^{\circ}\text{C}$ in compliance with LM-80-08

	CCT (t=0)	0hrs	1000hrs	2000hrs	3000hrs	4000hrs	5000hrs	6000hrs	7000hrs	8000hrs	9000hrs
1	2802K	0.5331	0.5327	0.5327	0.5323	0.5318	0.5315	0.5313	0.5310	0.5308	0.5307
2	2820K	0.5309	0.5304	0.5305	0.5301	0.5296	0.5293	0.5291	0.5288	0.5286	0.5283
3	2842K	0.5323	0.5317	0.5316	0.5312	0.5309	0.5307	0.5303	0.5301	0.5296	0.5292
4	2846K	0.5323	0.5320	0.5320	0.5316	0.5314	0.5311	0.5306	0.5303	0.5301	0.5298
5	2790K	0.5335	0.5331	0.5331	0.5327	0.5324	0.5322	0.5317	0.5313	0.5312	0.5308
6	2799K	0.5330	0.5327	0.5327	0.5323	0.5319	0.5316	0.5314	0.5311	0.5309	0.5305
7	2869K	0.5287	0.5282	0.5284	0.5279	0.5273	0.5272	0.5270	0.5266	0.5263	0.5260
8	2858K	0.5324	0.5319	0.5319	0.5315	0.5309	0.5308	0.5305	0.5301	0.5299	0.5295
9	2810K	0.5331	0.5327	0.5327	0.5323	0.5317	0.5314	0.5314	0.5309	0.5307	0.5303
10	2824K	0.5348	0.5346	0.5345	0.5341	0.5336	0.5332	0.5332	0.5327	0.5325	0.5320
11	2865K	0.5306	0.5302	0.5303	0.5298	0.5295	0.5291	0.5290	0.5286	0.5283	0.5279
12	2850K	0.5298	0.5293	0.5294	0.5283	0.5280	0.5277	0.5281	0.5277	0.5273	0.5268
13	2868K	0.5277	0.5271	0.5273	0.5268	0.5264	0.5261	0.5259	0.5256	0.5250	0.5245
14	2820K	0.5330	0.5328	0.5328	0.5324	0.5320	0.5318	0.5315	0.5313	0.5308	0.5304
15	2839K	0.5316	0.5311	0.5312	0.5307	0.5304	0.5301	0.5297	0.5296	0.5290	0.5285
16	2750K	0.5319	0.5313	0.5314	0.5310	0.5306	0.5303	0.5300	0.5299	0.5293	0.5288
17	2781K	0.5295	0.5289	0.5291	0.5286	0.5282	0.5280	0.5276	0.5274	0.5268	0.5263
18	2690K	0.5322	0.5318	0.5318	0.5314	0.5309	0.5306	0.5303	0.5302	0.5297	0.5291
19	2726K	0.5318	0.5312	0.5313	0.5308	0.5305	0.5302	0.5299	0.5298	0.5293	0.5288
20	2761K	0.5292	0.5286	0.5287	0.5281	0.5277	0.5274	0.5272	0.5269	0.5263	0.5258
21	2813K	0.5283	0.5274	0.5277	0.5271	0.5268	0.5265	0.5262	0.5261	0.5256	0.5250
22	2838K	0.5269	0.5261	0.5263	0.5259	0.5255	0.5253	0.5248	0.5245	0.5242	0.5237
23	2770K	0.5309	0.5304	0.5304	0.5300	0.5297	0.5294	0.5290	0.5288	0.5284	0.5279
24	2760K	0.5300	0.5294	0.5295	0.5289	0.5286	0.5284	0.5281	0.5277	0.5273	0.5267
25	2770K	0.5295	0.5289	0.5290	0.5286	0.5282	0.5280	0.5276	0.5272	0.5268	0.5264

Delta u'v' data for tested units

$T_s = T_{air} = 105^{\circ}\text{C}$, $I_f = 200\text{mA}$; $T_s \geq 103^{\circ}\text{C}$ and $T_{air} \geq 100^{\circ}\text{C}$ in compliance with LM-80-08

	CCT (t=0)	0hrs	1000hrs	2000hrs	3000hrs	4000hrs	5000hrs	6000hrs	7000hrs	8000hrs	9000hrs
1	2802K	0.0000	0.0016	0.0020	0.0022	0.0026	0.0030	0.0032	0.0036	0.0038	0.0038
2	2820K	0.0000	0.0017	0.0020	0.0022	0.0026	0.0030	0.0032	0.0037	0.0037	0.0038
3	2842K	0.0000	0.0025	0.0031	0.0032	0.0036	0.0039	0.0039	0.0044	0.0052	0.0055
4	2846K	0.0000	0.0016	0.0021	0.0021	0.0023	0.0026	0.0031	0.0035	0.0036	0.0039
5	2790K	0.0000	0.0020	0.0024	0.0025	0.0027	0.0031	0.0038	0.0042	0.0044	0.0047
6	2799K	0.0000	0.0015	0.0018	0.0019	0.0022	0.0026	0.0028	0.0033	0.0034	0.0038
7	2869K	0.0000	0.0016	0.0018	0.0020	0.0024	0.0027	0.0030	0.0036	0.0038	0.0039
8	2858K	0.0000	0.0019	0.0022	0.0023	0.0027	0.0029	0.0033	0.0039	0.0041	0.0045
9	2810K	0.0000	0.0018	0.0022	0.0023	0.0026	0.0030	0.0031	0.0038	0.0040	0.0043
10	2824K	0.0000	0.0014	0.0018	0.0018	0.0022	0.0027	0.0028	0.0034	0.0039	0.0044
11	2865K	0.0000	0.0015	0.0017	0.0020	0.0024	0.0028	0.0030	0.0034	0.0039	0.0043
12	2850K	0.0000	0.0015	0.0018	0.0019	0.0023	0.0027	0.0033	0.0037	0.0043	0.0048
13	2868K	0.0000	0.0018	0.0021	0.0024	0.0028	0.0032	0.0034	0.0039	0.0046	0.0050
14	2820K	0.0000	0.0014	0.0018	0.0018	0.0022	0.0025	0.0028	0.0033	0.0037	0.0041
15	2839K	0.0000	0.0018	0.0019	0.0021	0.0023	0.0028	0.0033	0.0035	0.0043	0.0048
16	2750K	0.0000	0.0016	0.0020	0.0021	0.0025	0.0029	0.0032	0.0034	0.0041	0.0048
17	2781K	0.0000	0.0017	0.0019	0.0023	0.0025	0.0029	0.0033	0.0036	0.0043	0.0050
18	2690K	0.0000	0.0016	0.0018	0.0020	0.0024	0.0029	0.0031	0.0034	0.0039	0.0047
19	2726K	0.0000	0.0018	0.0022	0.0026	0.0030	0.0032	0.0035	0.0037	0.0042	0.0048
20	2761K	0.0000	0.0016	0.0019	0.0025	0.0029	0.0034	0.0037	0.0044	0.0049	0.0055
21	2813K	0.0000	0.0021	0.0023	0.0026	0.0030	0.0034	0.0037	0.0040	0.0043	0.0051
22	2838K	0.0000	0.0018	0.0021	0.0023	0.0026	0.0030	0.0035	0.0038	0.0042	0.0048
23	2770K	0.0000	0.0016	0.0019	0.0020	0.0023	0.0027	0.0031	0.0034	0.0038	0.0045
24	2760K	0.0000	0.0016	0.0021	0.0024	0.0028	0.0031	0.0033	0.0040	0.0043	0.0051
25	2770K	0.0000	0.0018	0.0020	0.0022	0.0025	0.0028	0.0033	0.0039	0.0043	0.0048

Forward Voltage [V] data for tested units

$T_s = T_{air} = 105^{\circ}\text{C}$, $I_f = 200\text{mA}$; $T_s \geq 103^{\circ}\text{C}$ and $T_{air} \geq 100^{\circ}\text{C}$ in compliance with LM-80-08

	CCT (t=0)	0hrs	1000hrs	2000hrs	3000hrs	4000hrs	5000hrs	6000hrs	7000hrs	8000hrs	9000hrs
1	2802K	6.177	6.162	6.164	6.166	6.176	6.164	6.188	6.188	6.186	6.177
2	2820K	6.491	6.455	6.457	6.459	6.485	6.475	6.502	6.499	6.472	6.480
3	2842K	6.168	6.155	6.159	6.153	6.161	6.155	6.172	6.173	6.162	6.169
4	2846K	6.369	6.334	6.337	6.333	6.351	6.352	6.378	6.371	6.352	6.356
5	2790K	6.191	6.184	6.185	6.183	6.191	6.184	6.205	6.196	6.194	6.212
6	2799K	6.143	6.136	6.135	6.133	6.144	6.143	6.163	6.157	6.145	6.150
7	2869K	6.160	6.152	6.151	6.150	6.158	6.157	6.175	6.170	6.159	6.157
8	2858K	6.482	6.450	6.457	6.454	6.480	6.478	6.502	6.502	6.481	6.490
9	2810K	6.404	6.374	6.372	6.373	6.388	6.391	6.413	6.397	6.384	6.390
10	2824K	6.327	6.292	6.297	6.295	6.302	6.300	6.317	6.313	6.303	6.305
11	2865K	6.163	6.155	6.158	6.156	6.163	6.151	6.178	6.167	6.156	6.164
12	2850K	6.135	6.122	6.125	6.122	6.131	6.120	6.142	6.140	6.123	6.140
13	2868K	6.172	6.161	6.160	6.162	6.166	6.165	6.187	6.171	6.164	6.164
14	2820K	6.152	6.145	6.146	6.145	6.154	6.149	6.160	6.156	6.149	6.148
15	2839K	6.317	6.293	6.298	6.294	6.305	6.306	6.325	6.327	6.303	6.308
16	2750K	6.549	6.525	6.529	6.529	6.545	6.544	6.558	6.550	6.541	6.535
17	2781K	6.547	6.535	6.536	6.538	6.544	6.533	6.565	6.558	6.549	6.544
18	2690K	6.739	6.719	6.719	6.711	6.738	6.731	6.767	6.754	6.738	6.730
19	2726K	6.403	6.381	6.384	6.377	6.390	6.384	6.408	6.392	6.387	6.395
20	2761K	6.532	6.522	6.526	6.524	6.523	6.521	6.545	6.536	6.525	6.525
21	2813K	6.456	6.432	6.437	6.440	6.450	6.437	6.466	6.460	6.446	6.503
22	2838K	6.632	6.618	6.616	6.621	6.633	6.628	6.650	6.645	6.620	6.626
23	2770K	6.394	6.377	6.381	6.390	6.395	6.389	6.404	6.401	6.387	6.393
24	2760K	6.403	6.388	6.387	6.388	6.405	6.395	6.422	6.412	6.401	6.409
25	2770K	6.510	6.484	6.489	6.502	6.514	6.506	6.531	6.526	6.510	6.507

Company Information

Philips Lumileds is a leading provider of power LEDs for everyday lighting applications. The company's records for light output, efficacy and thermal management are direct results of the ongoing commitment to advancing solid-state lighting technology and enabling lighting solutions that are more environmentally friendly, help reduce CO2 emissions and reduce the need for power plant expansion. Philips Lumileds LUXEON LEDs are enabling never before possible applications in outdoor lighting, shop lighting, home lighting, digital imaging, display and automotive lighting.

Philips Lumileds is a fully integrated supplier, producing core LED material in all three base colors, (red, green, blue) and white. Philips Lumileds has R & D centers in San Jose, California and in the Netherlands, and production capabilities in San Jose, Singapore and Penang, Malaysia. Founded in 1999, Philips Lumileds is the high flux LED technology leader and is dedicated to bridging the gap between solid-state technology and the lighting world. More information about the company's LUXEON LED products and solid-state lighting technologies can be found at www.philipslumileds.com.